

TECHNICAL MANUAL

TRANSPORTABILITY GUIDANCE

**GUN, FIELD ARTILLERY, SELF-PROPELLED: 175-MM, M107
(NSN 2350-00-436-6635)**

**HOWITZER, HEAVY, SELF-PROPELLED: 8-INCH, MI10
(NSN 2350-00-439-6243)**

HOWITZER, HEAVY, SELF-PROPELLED: 8-INCH, MIIOE2

HEADQUARTERS, DEPARTMENT OF THE ARMY

MAY 1975

TRANSPORTABILITY GUIDANCE

GUN, FIELD ARTILLERY, SELF-PROPELLED: 175-MM, M107

(NSN 2350-00-436-6635)

HOWITZER, HEAVY, SELF-PROPELLED: 8-INCH, M110

(NSN 235 0-439-6243)

HOWITZER, HEAVY, SELF-PROPELLED: 8-INCH, M110E2

	Paragraph	Page
CHAPTER 1.	INTRODUCTION	
	Purpose and scope	1-1
	Reporting of recommendations and comments.....	1-2
	Safety	1-8
	Definitions of warnings, cautions, and notes.....	1-4
	2. TRANSPORTABILITY DATA	
Section I.	General	
	Scope	2-1
	Descriptions	2-2
Section II.	Characteristics and Related Data	
	General	2-3
	Side and rear elevation drawings	2-4
	Reduced configuration	2-5
	Unusual characteristics	2-6
	Hazardous and dangerous characteristics	2-7
	Sensitivity	2-8
	CONUS freight classification	2-9
CHAPTER 3.	SAFETY	
	General	3-1
	Specific safety requirements	3-2
	4. AIR TRANSPORTABILITY GUIDANCE	
	Scope	4-1
	Maximum utilization of aircraft	4-1
	Safety	4-8
	Preparation of vehicle	4-4
	Transport by US Air Force aircraft	4-5
	Transport by US Army aircraft	4-6
	5. HIGHWAY TRANSPORTABILITY GUIDANCE	
Section I.	General	
	Scope	5-1
	Safety	5-2
	General	5-3
Section II.	Transport by Semitrailer	
	Preparation	5-4
	Transport on semitrailer	6-5
	Transport on M747 semitrailer.....	5-6
CHAPTER 6.	MARINE AND TERMINAL TRANSPORTABILITY GUIDANCE	
Section I.	General	
	Scope	6-1

*This manual supersedes TM 55-230-216-20-1, 8 February 1967, and TM 55-2300-216-20-2, 12 May 1967.

	Paragraph	Page
	Safety	6-2 6-1
	Water shipment	6-3 6-1
Section	II. Loading and Securing	
	General	6-4 6-1
	Barges and lighters	6-5 6-4
	Landing ships, landing craft, and amphibians	6-4 6-4
	Barge-type ships (LASH) (SEABEE).....	6-7 6-5
CHAPTER	7. RAIL TRANSPORTABILITY GUIDANCE	
Section	I. General	
	Scope	7-1 7-1
	Maximum Utilization of Railcars.....	7-2 7-1
	II. Transport on CONUS Railways	
	General.....	7-8 7-1
	Preparation	7-4 7-1
	Loading on general-purpose flatcars	7-5 7-1
	Loading on special-purpose flatcars	7-6 7-1
	III. TRANSPORT ON FOREIGN RAILWAYS	
	General.....	7-7 7-8
	Transport on US Army-Owned Foreign Service	
	Flatcars.....	7-8 7-8
APPENDIX	A. CONVERSION TABLES	A-1
	B. REFERENCES	B-1
	QUESTIONNAIRE	

LIST OF ILLUSTRATIONS

Figure No.	Title	Page
2-1.	Gun, field artillery, self-propelled, 175-mm, M107	2-1
2-2.	Howitzer, self-propelled, 8-inch, M110 -.....	2-2
2-3.	Howitzer, self-propelled, 8-inch, M110E2.....	2-2
2-4.	Side elevation, Gun, M107, and howitzer, M110E2.....	2-4
2-5.	Side elevation, howitzer, M110.....	2-5
2-6.	Rear elevation, Gun, M107, and howitzers, M110 and M110E2	2-6
4-1.	Tiedown diagram of Gun, M107, and howitzers, M110 and M110E2, in C-S aircraft	4-2
6-1.	Blocking and tiedown diagram of typical gun, M107, on semitrailer, M747.....	6-2
5-2.	Turning diagram for gun, M107, loaded on semitrailer, M747, towed by truck-tractor, M123E2 -6	5-4
6-1.	Lifting diagram for howitzer, M110, using four-legged bridle sling.....	6-2
6-2.	Typical blocking and tiedown of howitzer, M110, in general cargo vessel	6-3
6-3.	Loading of four guns, M107, on LASH barge using wire rope, cable clamps, and turnbuckles with blocking between guns and guns to hull	6-6
7-1.	Blocking and tiedown diagram of typical gun, M107, on CONUS general-purpose flatcar (side view).....	7-2
7-2.	Blocking and tiedown diagram of typical gun, M107, on CONUS general-purpose flatcar (front view)	7-3
7-3.	Blocking and tiedown detail diagram.....	7-4
7-4.	Blocking and tiedown diagram of typical gun, M107, on CONUS HTTX or similar type of flatcar (side view)	7-5
7-5.	Blocking and tiedown diagram of typical gun, M107 on CONUS HTTX or similar type of flatcar (front view)	7-6

CHAPTER 1

INTRODUCTION

1-1. Purpose and Scope

a. This manual provides transportability guidance for logistical handling and movement of the gun, self-propelled, M107, and howitzer, self-propelled, M110 and M10E2. The National Stock Number, Line Item Number, and permanent model number were not available on the publication date of this manual. These numbers will be provided, when available, in a change to this manual.

b. The intent of this manual is to provide transportation officers and other personnel responsible for movement or providing transportation services with information considered appropriate for safe transport. Significant technical and physical characteristics as well as safety considerations required for worldwide movement by the various modes of transportation are included. When considered appropriate, metric equivalents are given in parentheses following dimensions or other measurements. Conversion tables are contained in Appendix A.

1-2. Reporting of Recommendations and Comments

The reporting of errors, omissions, and recommendations for improving this manual by the individual user is encouraged. Reports should be submitted on DA Form 2028 (Recommended Changes to DA Publications and Blank Forms) and forwarded to Director, Military Traffic Management Command Engineering

Agency, ATTN: MTT-TRP, P. O. Box 6276, Newport News, Virginia 23606.

NOTE

Attention is invited to the stamped and preaddressed tear-out questionnaire following appendix B. Request that this questionnaire be completed and mailed within 6 months of the manual publication date.

1-3. Safety

Appropriate precautionary measures required during movement of the items are contained in chapter 3.

1-4. Definitions of Warnings, Cautions, and Notes

Throughout this manual, warnings, cautions, and notes emphasize important or critical guidance. They are used for the following conditions:

a. *Warning.* An operating procedure or practice that, if not correctly followed, could result in personal injury or loss of life.

b. *Caution.* An operating procedure or practice that, if not strictly observed, could result in damage to or destruction of equipment.

c. *Note.* An operating procedure or condition that must be emphasized.

CHAPTER 2

TRANSPORTABILITY DATA

Section I. GENERAL

2-1. Scope

This chapter provides a general description of the self-propelled gun and howitzers, identification photographs, tabulated transportability characteristics, and data that are necessary for movement.

2-2. Descriptions

a. General. The gun, M107, and howitzers, M110 and M110E2, are full-tracked, self-propelled, combat vehicles. They are powered by liquid-cooled, compression ignition engines. Power is transmitted

to the final drive through a cross-drive transmission, differential, steering, and braking unit. The vehicles are supported by a torsion bar suspension system.

b. M107 (fig 2-1). The M107 is equipped with a 175-mm cannon, M113.

c. M110 (fig 2-2). The M110 is equipped with an 8-inch howitzer, M2A1E1.

d. M110E2 (fig 2-4). The M110E2 is equipped with an 8-inch howitzer.

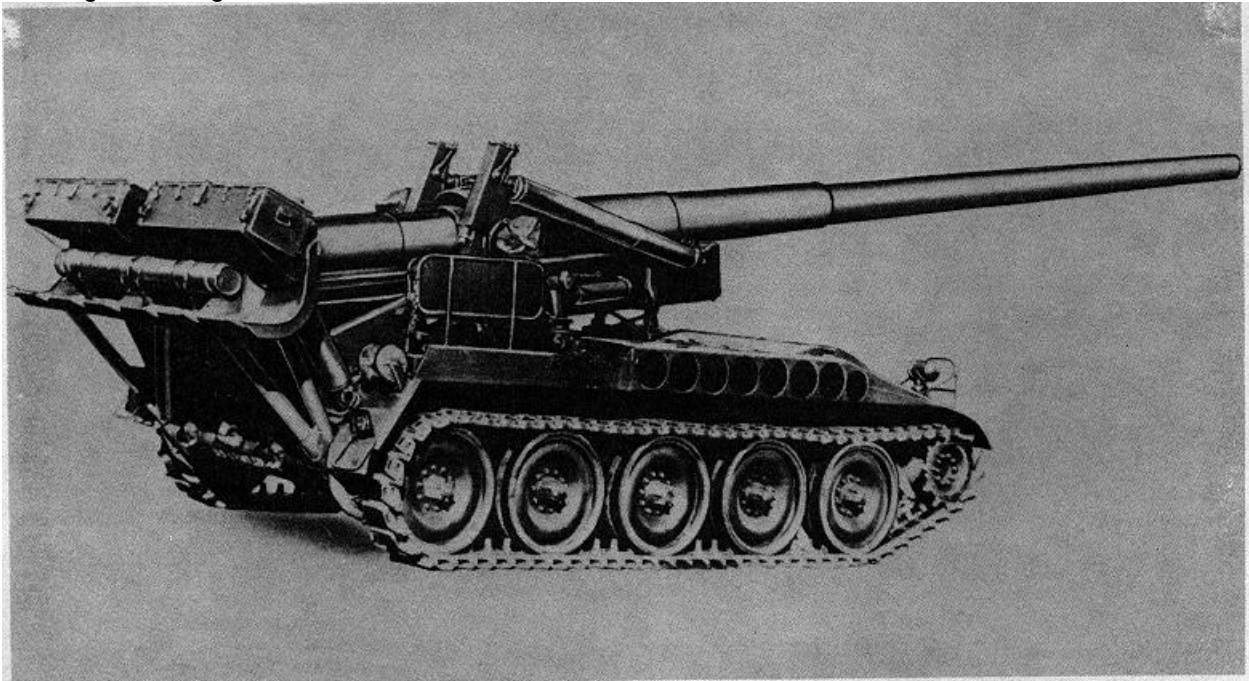

Figure 2-1. Gun, field artillery, self-propelled, 175-mm, M107.

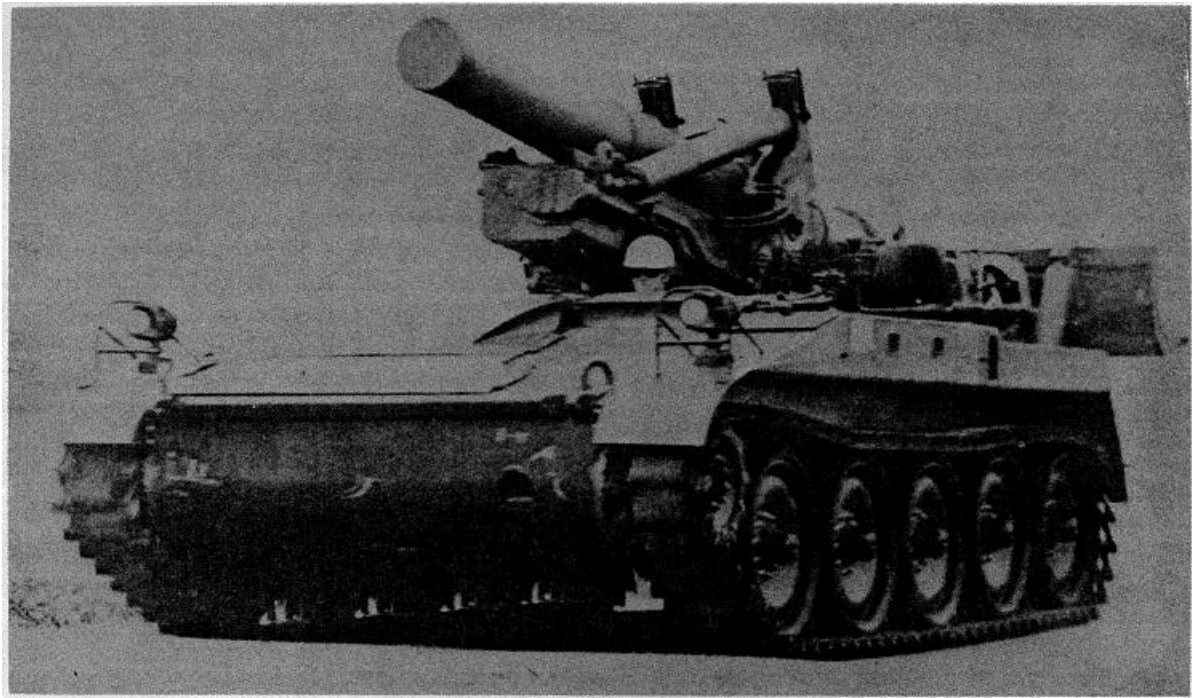

Figure 2-2. Howitzer, self-propelled, 8 inch, M110



Figure 2-3. Howitzer, self-propelled, 8-inch, M110E2.

Section II. CHARACTERISTICS AND RELATED DATA

2-3. General

Data contained in figures 2-4 through 2-6 and table 2-1 are applicable to model number or National stock number (NSN) shown. Changes in model or NSN may affect transportability as related to guidance contained in this manual.

2-4. Side and Rear Elevation Drawings

Detailed side and rear elevation drawings (fig 2A2-26) provide data necessary for determining transportability of the gun and howitzers by the various modes of transportation.

2-5. Reduced Configuration

Transportation economies can be obtained by reducing each gun or howitzer to its minimum dimensions for terminal handling and ocean transport. The M107, M110, and M110E2 can be reduced by securing the gun tube at zero elevation in the shipping position.

2-6 Unusual Characteristics

The gun and howitzers have no unusual characteristics that require special attention be given to temperature, atmospheric pressure, or humidity variations during exposure to normal transportation environments.

2-7. Hazardous and Dangerous Characteristics

Unless the gun or howitzers are shipped with ammunition under the provisions of Department of Transportation Special Permit No. 3498 (applicable to shipments in periods of actual national emergency), they will not present any hazardous or dangerous characteristics during exposure to normal transportation environments.

NOTE

Those regulations and/or transportation procedures normally associated with vehicles containing diesel fuel will apply (app B).

2-8. Sensitivity

The gun and howitzers are so designed that when restrained in accordance with the guidance contained in this manual they can withstand the shocks and vibrations associated with current transportation methods.

2-9. CONUS Freight Classification

Rail and motor freight classification descriptions and item numbers will be determined in accordance with chapter 211, AR 55-355. Proper classification and/or description of articles must be determined and provided on the bill of lading before shipments are released to carriers.

Table 2-1. Characteristics and Related Data

Model	TOE LIN	NSN (2350)	Weight.lb (kg)	Volume, cu ft (cu m)	
				Operational	Reduced
M107	J97230	00-436-6635	59,200 (26,853)	4,473 (126.59)	3,425 (96.93)
M110	K56981	00-439-6243	57,630 (26,141)	2,296 (64.98)	2,046 (57.96)
M110E2			60,200 (27,307)	3,947 (111.70)	3,473 (98.29)

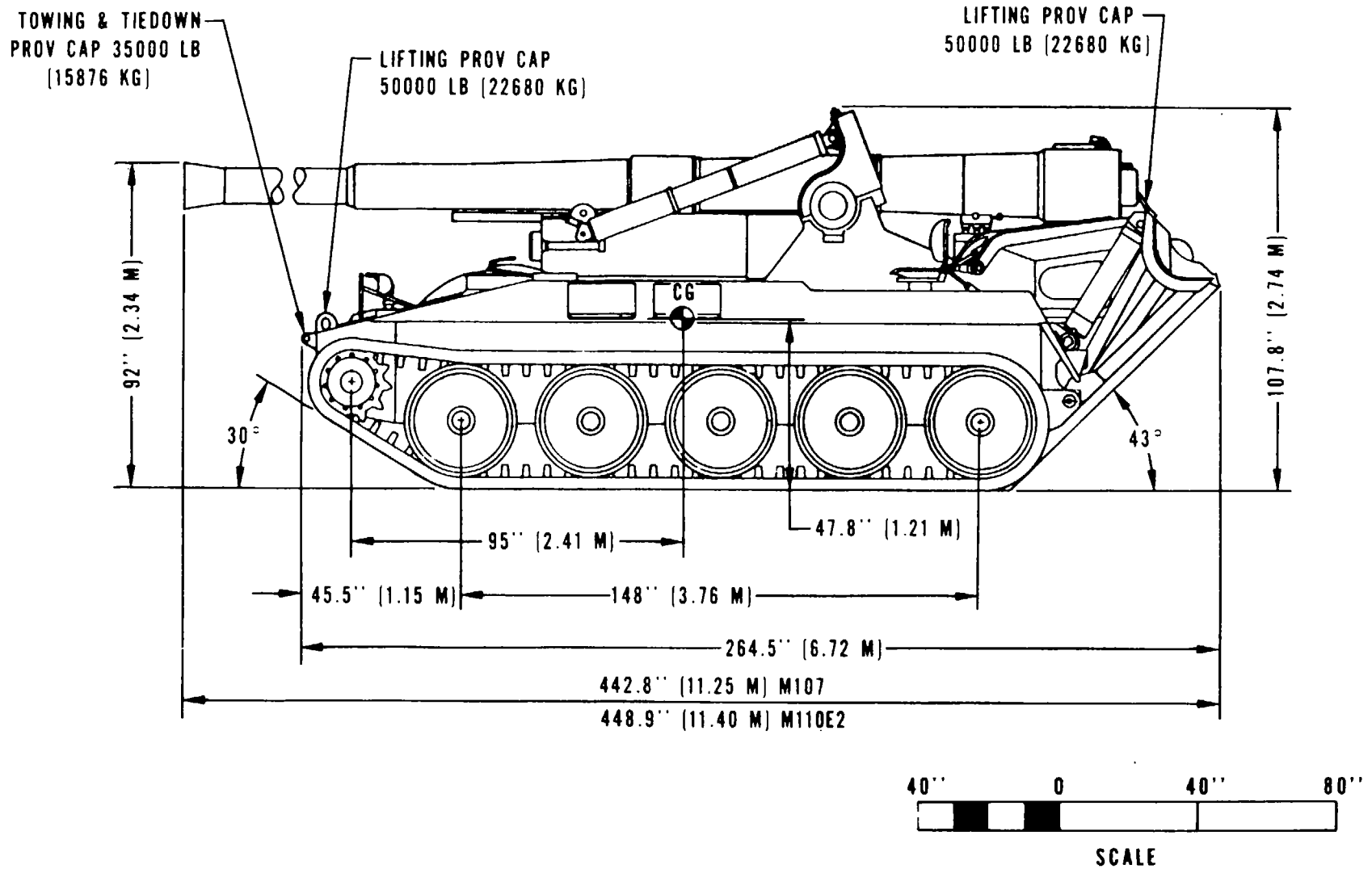

Figure 2-4. Side elevation, gun, M107, and howitzer, M110E2.

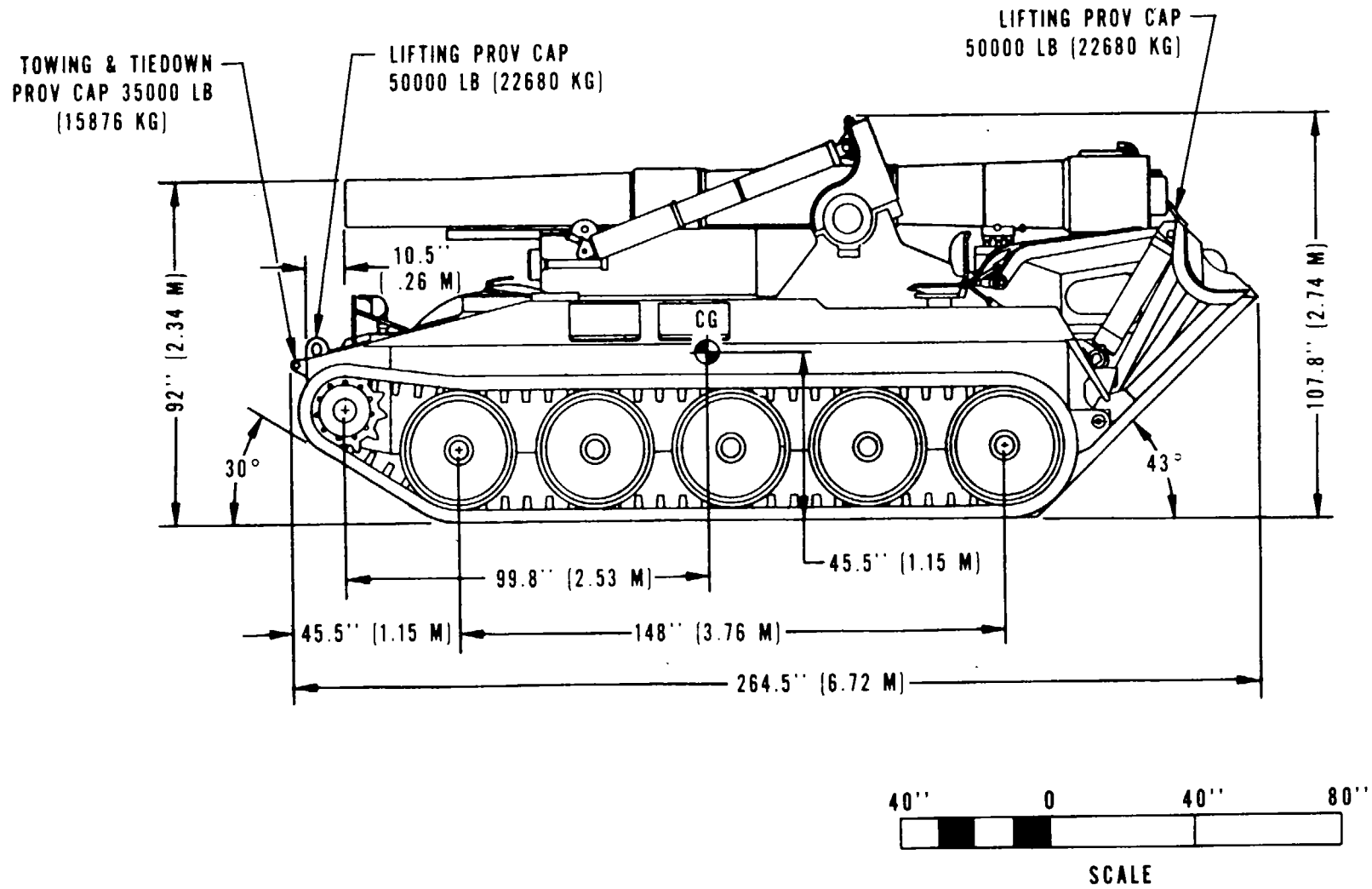

Figure 2-5. Side elevation, howitzer, M110.

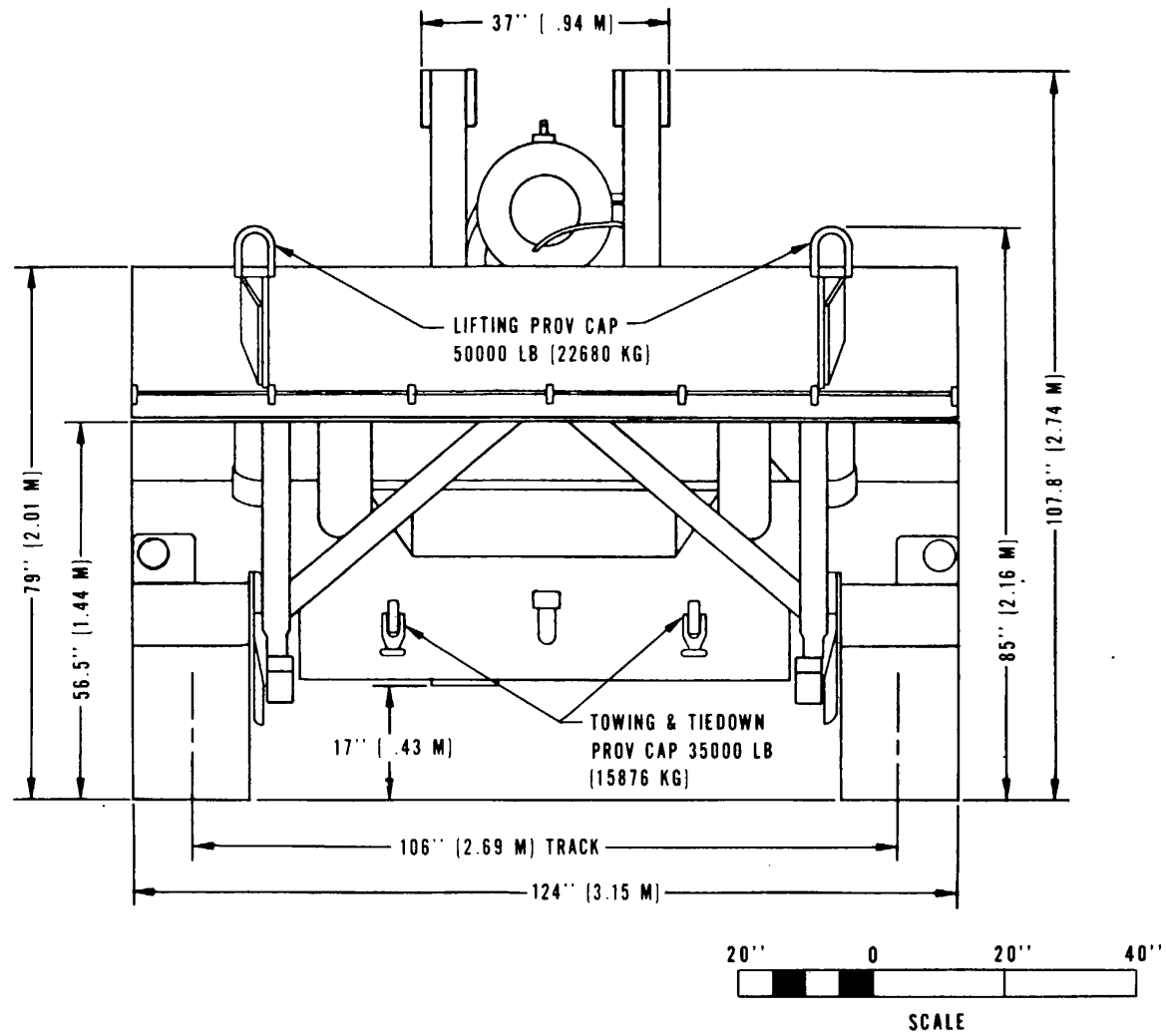

Figure 2-6. Rear elevation, gun, M107, and howitzers, M10 and M110E2.

CHAPTER 3**SAFETY**

3-1. General

General safety considerations and precautions for movement are as follows:

- a. Check each vehicle to insure that all loose items are appropriately secured.
- b. When backing a vehicle, insure that no personnel or obstacles are behind it.

WARNING

Fire extinguishers must be readily available during all loading and unloading operations.

WARNING

Proper ventilation must be provided during loading and unloading operations if vehicle engine is used. Prolonged inhalation of carbon monoxide fumes will produce adverse effects that could prove fatal.

3-2. Specific Safety Requirements

Pertinent safety requirements by individuals modes of transportation can be found, where applicable, in the appropriate chapters.

CHAPTER 4

AIR TRANSPORTABILITY GUIDANCE

4-1. Scope

This chapter provides transportability guidance for air movement of the gun, M107, and howitzers, M110 and M110E2. It covers significant technical and physical characteristics and safety considerations and prescribes the manpower, materials, and time required to prepare, load, and unload the gun and howitzers as internal loads aboard US Air Force aircraft.

4-2. Maximum Utilization of Aircraft

The loads described in this chapter are not maximum loads. Total cargo loads and operating ranges in nautical miles are provided in AR 70-39.

4-3. Safety

In addition to the safety precautions contained in chapter 3, the following should be noted:

- a. The activity offering the gun or howitzers for air transport will notify the aircraft commander or his designated representative in the event ammunition or explosives are to be transported within the gun or howitzers.
- b. The vehicle fuel tanks must not be more than three-fourths full.
- c. The gun or howitzers must be restrained for air transport in accordance with the applicable procedures in Section IV of Air Force TO 1C-5A-9. Procedures outlined in this manual are for general information.

WARNING

Fire extinguishers must be readily available during all loading and unloading operations.

WARNING

Proper ventilation must be provided when loading and unloading. Prolonged inhalation of carbon monoxide fumes may be fatal.

CAUTION

Do not allow vehicle to exceed 3 miles

per hour inside aircraft or on loading ramps.

4-4. Preparation of Vehicle

- a. Gun traverse and elevating mechanism must be in travel position, locked, and wire-tied to prevent movement. Spade will be locked in the travel position.
- b. Remove or secure all loose material.

4-5. Transport by US Air Force Aircraft

- a. The M107, M110, and M110E2 are air transportable in C-5 aircraft.
- b. The aircraft commander or his representative is responsible for insuring that the gun or howitzer, M107, M110, and M110E2, are on/off loaded and properly secured in the aircraft in accordance with the criteria in Section IV of TO 1C-5A-9.
- c. Metal parts of the gun or howitzer track must not make contact with the aircraft loading ramp or cargo compartment floor. Inconsistencies in the rubber track pad thicknesses and available contact area after prolonged vehicle operation prohibit on/off loading of the gun or howitzers without showing. Adequate wood showing for rolling and parking of the vehicle will be used to protect the aircraft floor surfaces.
- d. Restraint factors (g loads) for minimum acceptable conditions specified for crew and passenger safety in the event of a controlled emergency landing are specified in AR 70-39 and TO 1C-5A-9. Tiedown diagram (fig 4-1) and data table (table 4-1) are based on acceptable methods and can be used as a guide. Figure 4-1 shows a representative pattern. Table 4-1 lists the tiedown devices required (provided aboard aircraft), tiedown points on the gun or howitzers, and corresponding fittings on the aircraft to which devices are secured.
- e. When the gun or howitzer has been positioned aboard the aircraft, the transmission should be placed in neutral and the parking brake set.

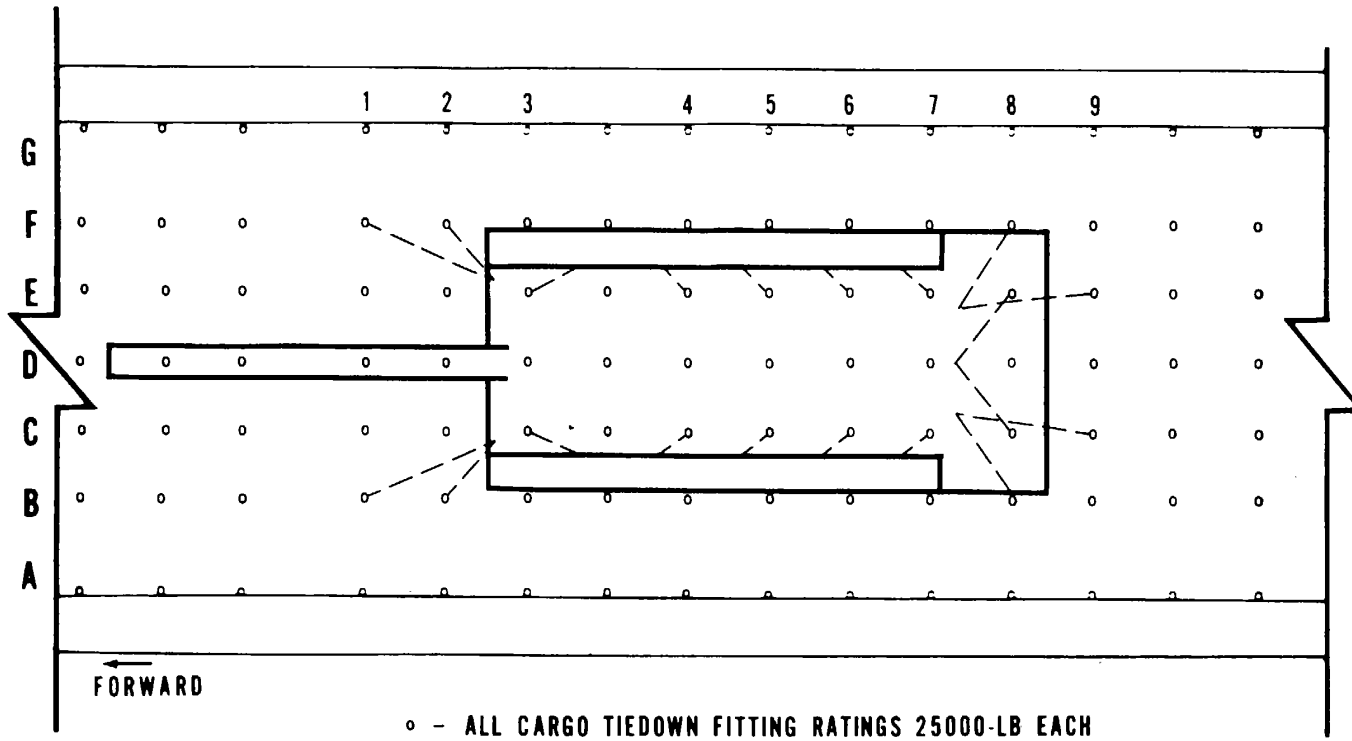

Figure 4-1. Tiedown diagram for gun, M107, and howitzers, M110 and M110E2 in C-5 aircraft.

f. Four men can prepare, load, and tie down one gun or howitzer in approximately 45 minutes. Three men can remove tiedowns and unload one gun or howitzer in approximately 15 minutes.

considered for loading with the gun or howitzer.

WARNING

Consult TM 38-250 (AFM 71-4) to insure compatibility of any cargo being

4-6. Transport by US Army Aircraft

The gun, M107 and howitzers, M110 and M107E2 exceed the size and weight limitations for internal or external transport by US Army fixed-wing or rotary-wing aircraft.

Table 4-1. Tiedown Data for Gun, M107, and Howitzers, Milo and M110E2 in C-5 Aircraft

designation	Tiedown fitting	Tiedown device*		Attach to item
	capacity	type	Capacity	
	in 1,000 lb		in 1,000 lb	
B1	25	MB-2	25	Left front tiedown
F1	25	MB-2	25	Right front tiedown
B2	25	MB-2	25	Left front tiedown
F2	25	MB-2	25	Right front tiedown
C3	25	MB-2	25	Left No.1 road wheel axle
E3	25	MB-2	25	Right No.1 road wheel axle
C4	25	MB-2	25	Left No.2 road wheel axle
E4	25	MB-2	25	Right No.2 road wheel axle
CS	25	MB-2	25	Left No.3 road wheel axle
ES	25	MB-2	25	Right No.3 road wheel axle
C6	25	MB-2	26	Left No.4 road wheel axle
E6	25	MB-2	25	Right No.4 road wheel axle
C7	25	MB-2	25	Left No.5 road wheel axle
E7	25	MB-2	25	Right No.5 road wheel axle
B8	25	MB-2	25	Left rear hull tiedown
C8	25	MB-2	25	Towing pintle
E8	25	MB-2	25	Towing pintle
F8	25	MB-2	25	Right rear hull tiedown
C9	25	MB-2	25	Left rear hull tiedown
E9	25	MB-2	25	Right rear hull tiedown

*Tiedown device D1 may be substituted for MB-2.

CHAPTER 5

HIGHWAY TRANSPORTABILITY GUIDANCE

Section I. GENERAL

5-1. Scope

This chapter provides transportability guidance for highway movement of the gun, M107, and howitzers, M110 and M109. It covers significant technical and physical characteristics and safety considerations and prescribes the materials required to prepare and load the gun or howitzers on semitrailers.

5-2. Safety

In addition to safety precautions contained in chapter 3, CONUS movement is subject to all safety laws, rules, and regulations applicable to commercial carriers. In overseas areas movements are governed by theater regulations.

CAUTION

Do not allow gun or howitzer to exceed 3 miles per hour during loading or unloading.

5-3. General

The gun and howitzers are considered self-deliverable only under appropriate tactical situations. Although the vehicle tracks are equipped with rubber pads, movement over paved public highways will not be made without specific approval as outlined in AR 5-162. The weight of the gun and howitzers is considered excessive for some bridges and will require special routing.

Section II. TRANSPORT BY SEMITRAILER

5-4. Preparation

a. Gun traverse and elevating mechanisms must be in travel position, locked, and wire-tied to prevent movement.

b. Remove all basic issue items from exterior of gun or howitzer and secure inside of stowage compartments or separate box.

5-6. Transport on M747 Semitrailer

a. General. For purposes of illustration the gun, M107, is shown as a typical load on the semitrailer, M747 (fig 5-1).

b. Material. Adequate tiedown chains and binders for securing the gun are carried aboard the semitrailer, M747, as basic issue items.

c. Loading.

WARNING

At no time during loading operations should personnel be on trailer bed.

WARNING

Loading should not be conducted on side or lateral slopes exceeding 10 percent or with a tractor-to-trailer offset angle greater than 5 degrees. Avoid loading on a severe downgrade to prevent the payload from rolling forward on the trailer.

(1) Position curbing assemblies on trailer bed so that they will be against inside edge of both

5-5. Transport on Semitrailer

The gun, M107, and howitzers, M110 and M109, may be transported over highways loaded on semitrailers. Movement over public highways in CONUS and overseas should be made only when other modes of transport are not available. Highway shipments may be made using either military or commercial low-bed semitrailers of adequate capacity. Tractors and semitrailers large enough to transport the gun or howitzers normally exceed length, width, and weight limitations in CONUS and overseas. Special permits are required in CONUS (AR 55-162), and special routing is required overseas for outsize/overweight shipments.

tracks when gun or howitzer is aboard trailer (item A, fig. 5-1).

(2) Drive or winch gun or howitzer onto the trailer bed. The M107 and M110E2 should be positioned as shown in figure 5-1 so that the muzzle end of the barrel does not protrude beyond the front end of the trailer in a manner that would interfere with the towing tractor. The M110 should be placed to the farthest forward position against the wood bumpers (item B, fig 5-1). TM 9-2830-294-14 contains detailed instructions for winching operations.

(3) Place and wire-tie transmission in neutral position. Set parking brakes.

d. Tiedowns.

(1) Figure 5-1 provides a tiedown diagram that is compatible with standard loading practices and will adequately restrain the load against forces encountered at normal speeds and operating conditions.

(2) Attach chain (item C, fig 5-1) to left front towing shackle and pass through winch roller (item D, fig 5-1). Attach load binder to tiedown shackle on trailer goose neck (item E, fig 5-1). Attach chain to load binder and tighten. Repeat on right side. Attach chain to left rear towing shackle. Attach load binder to rearmost tiedown fitting on right side of trailer. Attach chain to load binder and tighten. Repeat on other side.

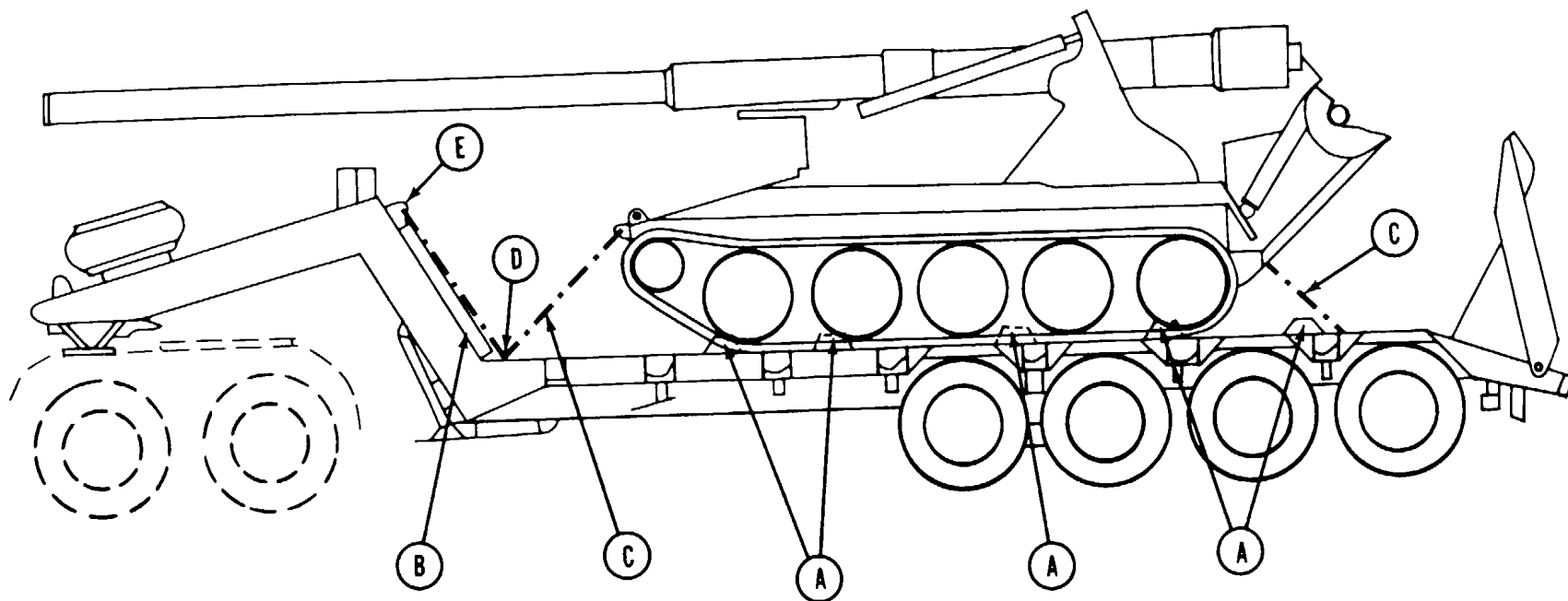

Figure 5-1. Blocking and tiedown diagram of typical gun, M107, on semitrailer, M747.

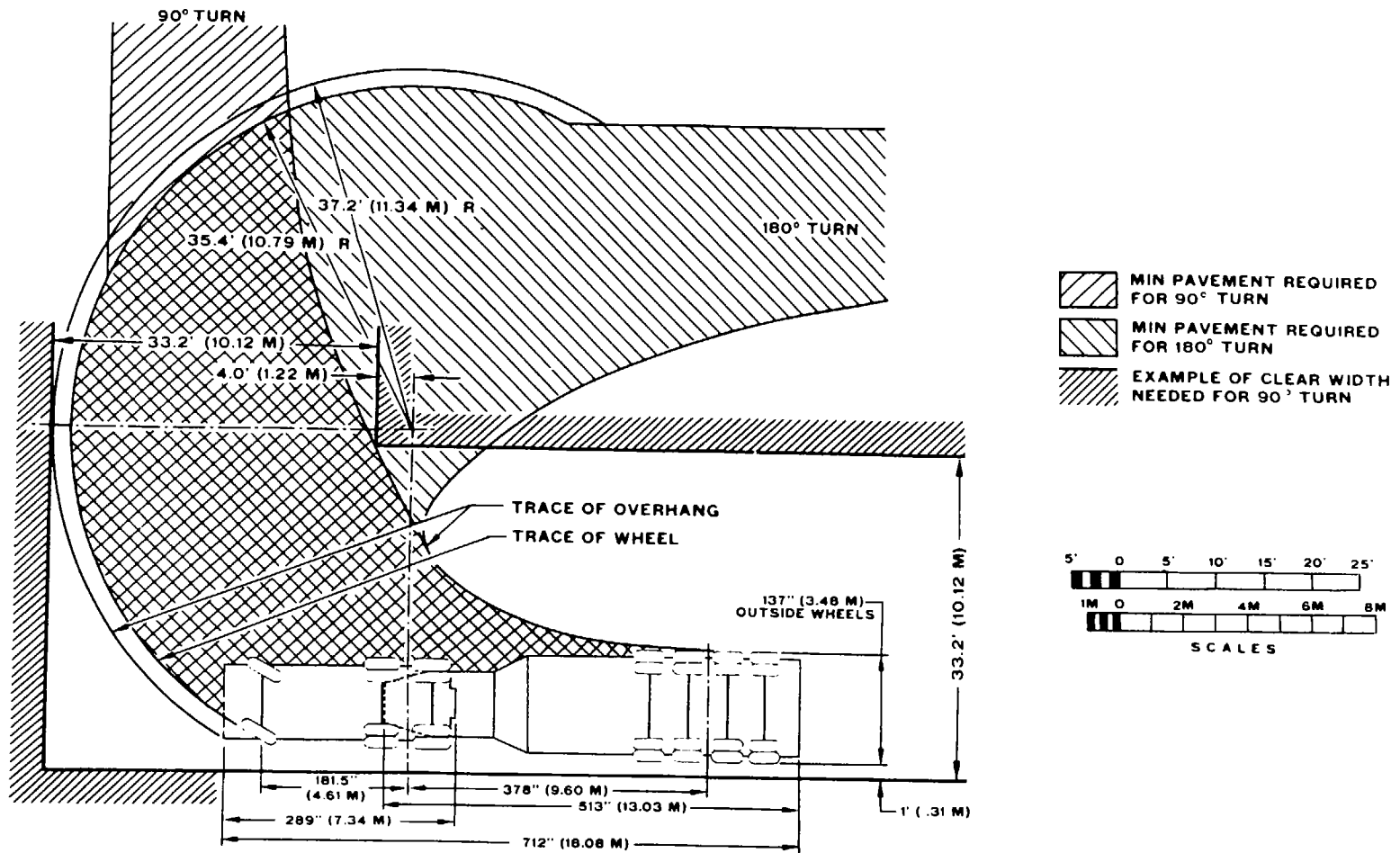

Figure 5-2. Turning diagram for gun, M107, loaded on a semitrailer, M747, towed by truck-tractor, M123E2.

CHAPTER 6

MARINE AND TERMINAL TRANSPORTABILITY GUIDANCE

Section I. GENERAL

6-1. Scope

This chapter provides transportability guidance for marine and terminal movement of the gun, M107, and howitzers, M110 and M110E2. It covers significant technical and physical characteristics and safety considerations and prescribes the materials and guidance required to prepare, lift, tie down, and discharge the gun or howitzers.

6-2. Safety

In addition to the safety precautions contained in chapter 3, the following should be noted as applicable:

a. The activity offering the gun or howitzer for transport will notify the carrier in the event ammunition or explosives are to be transported with the item. Compliance with AR 55-228, paragraph 2-7 is mandatory.

b. Ammunition and vehicles will be handled and stowed in accordance with Water Carrier Tariff No. 27 or reissues thereof.

c. Fire extinguishers must be available during all loading and discharge operations.

d. Vessel equipment and gear should be inspected before being used.

e. Stevedore slings and other items used in the loading and discharge operations should be inspected for condition and adequate capacity.

f. Personnel should be cautioned not to walk under items being lifted.

g. Lifting eyes and shackles on each gun or howitzer should be inspected to insure that they are complete and not damaged.

h. All lifts should have at least two tag lines attached to control the swing of the lift while suspended.

6-3. Water Shipment

The gun and howitzers can be transported by a variety of inland-waterway cargo carriers, lighters, and by most seagoing cargo vessels.

NOTE

The methods described in this chapter for lifting and securing are suggested procedures. Other methods of handling and stowage may be used provided they will insure safe delivery without damage.

Section II. LOADING AND SECURING

6-4. General Rules

a. Stowage. Whenever possible, below-deck stowage should be provided. In general, good stowage means placing the guns or howitzers as close together as practical with minimum space between outer item and sweatboards (approximately 4 to 6 inches); breakable parts protected; spare parts stowed in or near parent item; brakes set with brake lever wire-tied; transmission in neutral with control lever wire-tied; battery terminals disconnected and taped; and fuel tanks drained. Secure by blocking tracks front and rear on both sides; lash with wire rope or chains to bulkhead, stanchions, or padeyes.

NOTE

1. When guns or howitzers are loaded on vessels that are adequately ventilated by power blowers, such as roll-on/ roll-off vessels, fuel need not be drained.
2. Tracked vehicles may arrive at the terminal with access hatches welded shut to prevent pilferage. Since these vehicles are not maneuverable under

their own power, brakes are not set and transmissions are in the neutral position to permit towing in the loading area.

each upper front corner of the hull and each end of the upper edge of the spade for a total of four. A typical lifting diagram is shown in figure 6-1.

b. Lifting. Correct lifting points on the M107, M110, and M10E2 are the lifting eyes located at

c. Loading. Guns and howitzers will be loaded on vessels in their minimum configuration as described in paragraph 2-5. They may be loaded

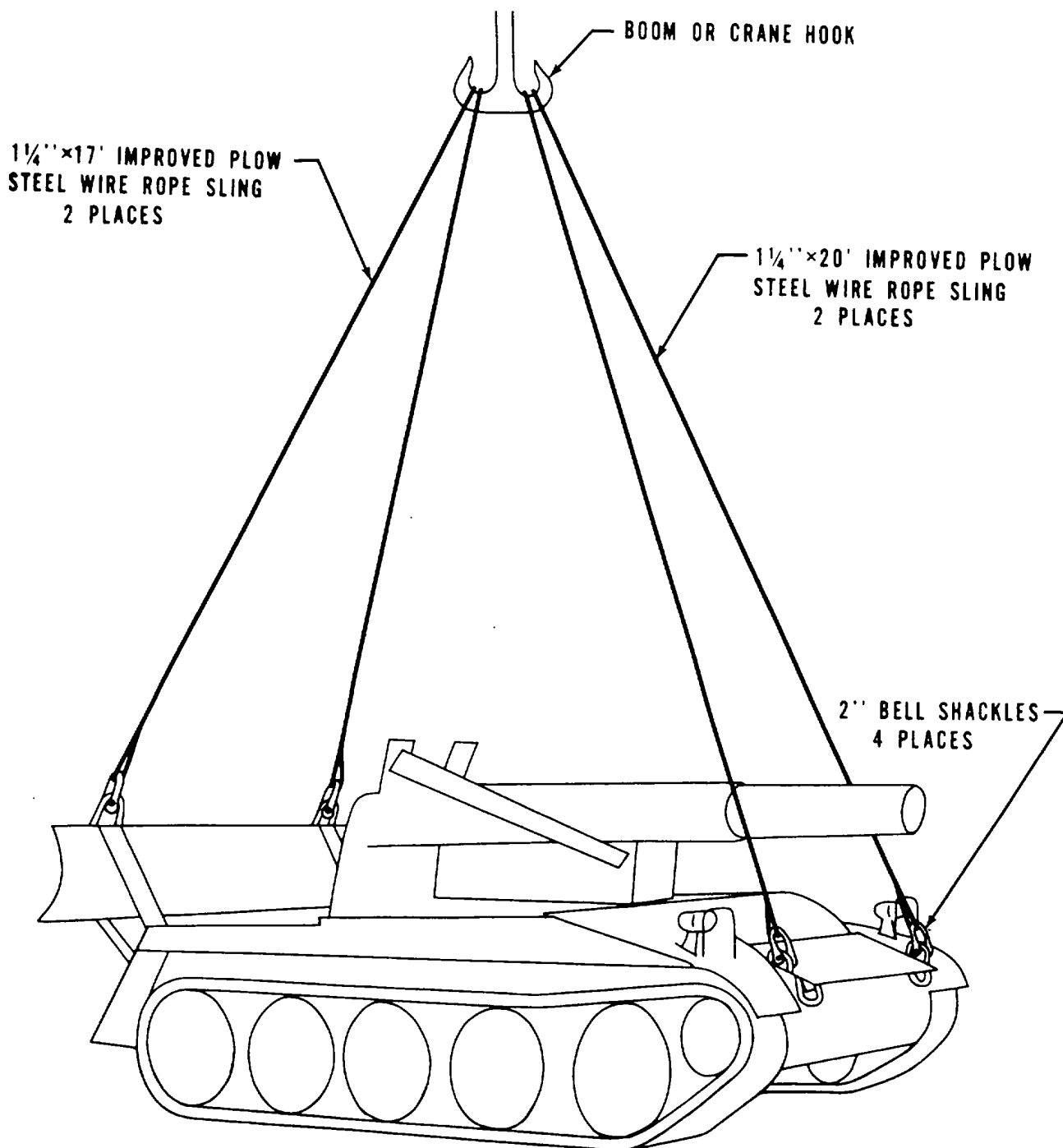

Figure 6-1. Lifting diagram for howitzer, M10, using four-legged bridle sling.

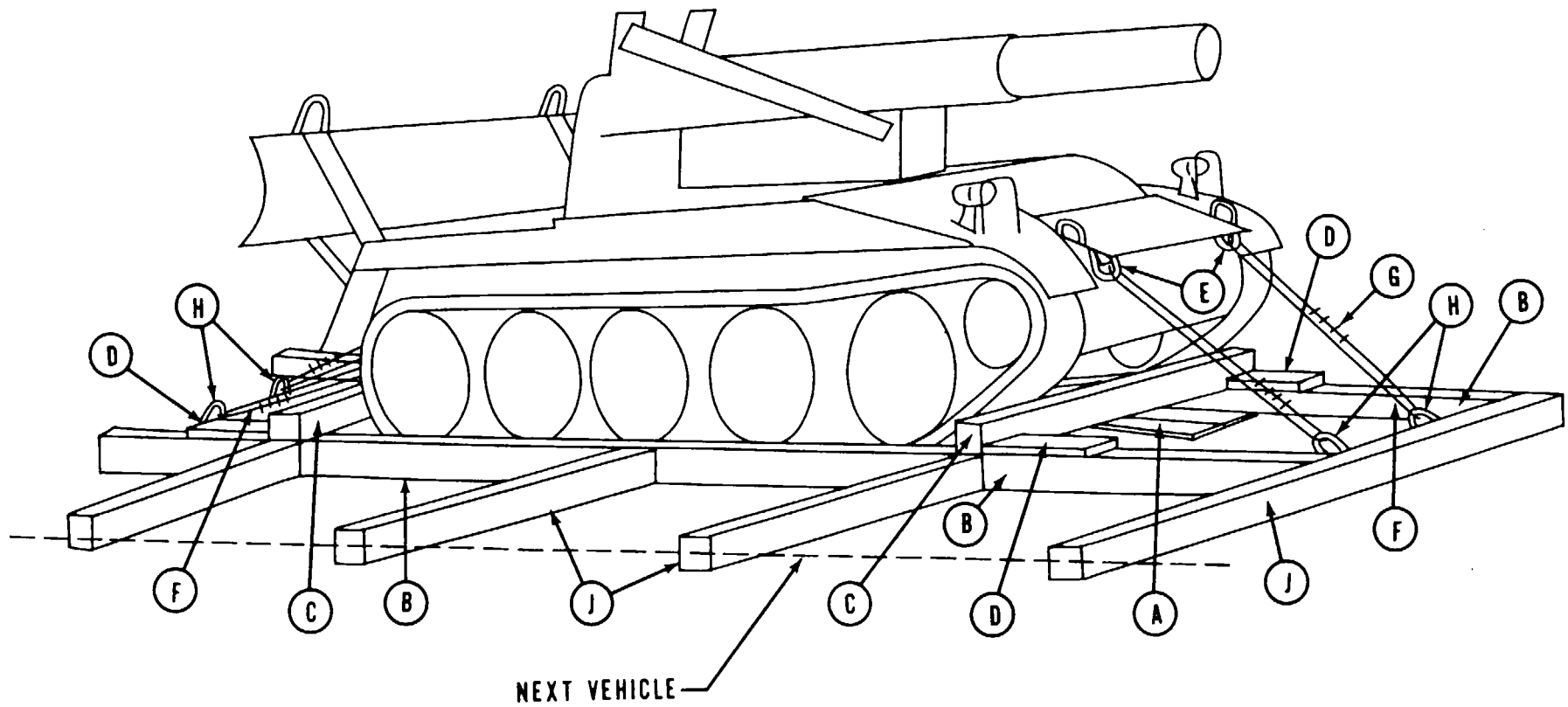

Figure 6-2. Typical blocking and tiedown of howitzer, M110, in general cargo vessel.

aboard landing craft, beach discharge lighters, heavy amphibious lighters, and landing ships under their own power or by crane of adequate capacity. They can also be loaded under their own power onto the deck of barges from a pier when tidal conditions are suitable and ramps are available. They can be loaded onto seagoing vessels by shoreside or floating cranes of adequate

capacity or by heavy-lift ship's gear. Guns or howitzers can be driven or towed aboard tiedown roll-on/roll-off vessels. Figure 6-2 shows typical blocking and tiedown details. Tables 6-1 and 6-2 list materials and their application.

Table 6-1. Bill of Materials for Blocking and Tiedown of Typical Howitzer, M110, in General Cargo Vessel (Fig 6-2)

Item	Description	Approximate quantity
Lumber	Douglas-fir, or comparable lumber, straight-grain, free from material defects; Fed Spec MM-L-751H 4- x 6-in. 2- x 12-in. 6- x 8-in.	5 linear ft 60 linear ft 100 linear ft
Nails	Common, steel; flathead; bright or cement-coated; table XI-b, Fed Spec FF-N-105B: 40d	120
Wire Rope	6X19, IWRC, improved plow steel; preformed, regular-lay; table X, Fed Spec RR-W-410C: %-in.	60 ft
Clamps	Wire rope, U-bolt clips, saddled, single grip, steel, Crosby heavy-duty, or equal; MIL-STD 16842: %-in.	16
Shackles	Clevis assembly, suspension, bolt and nut type, large, NSN 1670-00-090-5354, or equal (for front and rear towing and tiedown provisions).	4

Table 6-2. Application of Materials for Blocking and Tiedown of Typical Howitzer, M110, in General Cargo Vessel (Fig 6-t)

Item	No. required	Application
A	4	Lumber, 2- x 12- x 168-in. Pre-position on vessel deck so that two pieces will be under each howitzer track.
B	2	Side blocking. Each to consist of 6- x 8- x 288-in. lumber. Locate one piece on each side of howitzer against outside edge of tracks.
C	2	End blocking. Each to consist of 6- x 8- x 140-in. lumber. Locate on top of item B and against tracks front and rear. Toenail to item B with four 40d nails at each end.
D	4	Backup cleats Each to consist of 4- x 6- x 12-in. lumber. Locate on top of item B against item C. Toenail to item B with four 40d nails.
E	4	Shackles. Secure one shackle to each towing lug (two at front and two at rear of howitzer).
F	4	Wire rope, 15 ft. Make a complete loop through shackle and padeye; secure with clamps (item G).
G	16	Clamps, %-in. Use four to secure each item F.
H	4	Padeyes. Built into vessel deck.
J	As required	Bracing, 6- x 8-in. by length-to-suit. Brace as required against adjacent vehicle, cargo, or side of vessel bulkhead blocking. Secure each end of each piece to adjacent blocking or bracing by toe nailing with four 40d nails.

d. Special Design. Seatrain ships, roll-on/rolloff ships, landing ships, and attack cargo ships are equipped with patented lashing gear and prepositioned fittings in the decks. The use of such equipment is adequate, and additional blocking and bracing is not required.

6-5. Barges and Lighters

When transporting the gun or howitzers by barge or similar lighterage to or from vessels secured to piers or at a sheltered anchorage, blocking and

chocking will be required. When moving extended distances or through rough waters, tiedowns must also be used.

6-6. Landing Ships, Landing Craft, and Amphibians

When transporting the gun or howitzers for extended distances or through rough waters, blocking and tiedowns must be used. In most cases the vessels are equipped with turnbuckles with a sheep's foot fitting on one end that fits into a

deck cloverleaf. Where not provided, a suitable substitute may be used.

6-7. Barge-Type Ships (LASH) (SEABEE)

a. General. Figure 6-3 illustrates a typical loading diagram of the M107 gun loaded on a barge for transport aboard a barge-type ship. Barge stability is noticeably affected by the loading of heavy-lift items, and tracked vehicles should be loaded symmetrically in sequence about the center line of the barge or lighter. The howitzers should be loaded in a manner to counterbalance variations in centers of gravity; that is, alternate head to tail.

b. *Dunnage*. Dunnage is not generally used beneath the tracks of vehicles equipped with rubber track pads. Frictional forces between the pads and deck are sufficient to make it unneces-

sary. However, deck surfaces should be dry and free from grease or debris.

c. Blocking. The gun and howitzers can be adequately blocked and braced with 6x 8-inch timbers. Blocking should be installed as a separator between the tracks and barge bulkheads. Blocking is normally installed in front and rear of the tracks and the bracing part force-fitted to the bulkhead. Loading, blocking, and bracing proceed from the outer areas of the barge toward the center, which is loaded last. Separator timbers are installed against the bulkhead or track and the next gun or howitzer loaded is placed firmly against the timber. Any void area remaining in the center of the barge after the last gun or howitzer is loaded is filled by cut and force-fitted blocking. Lumber specifications are listed in table 6-1.

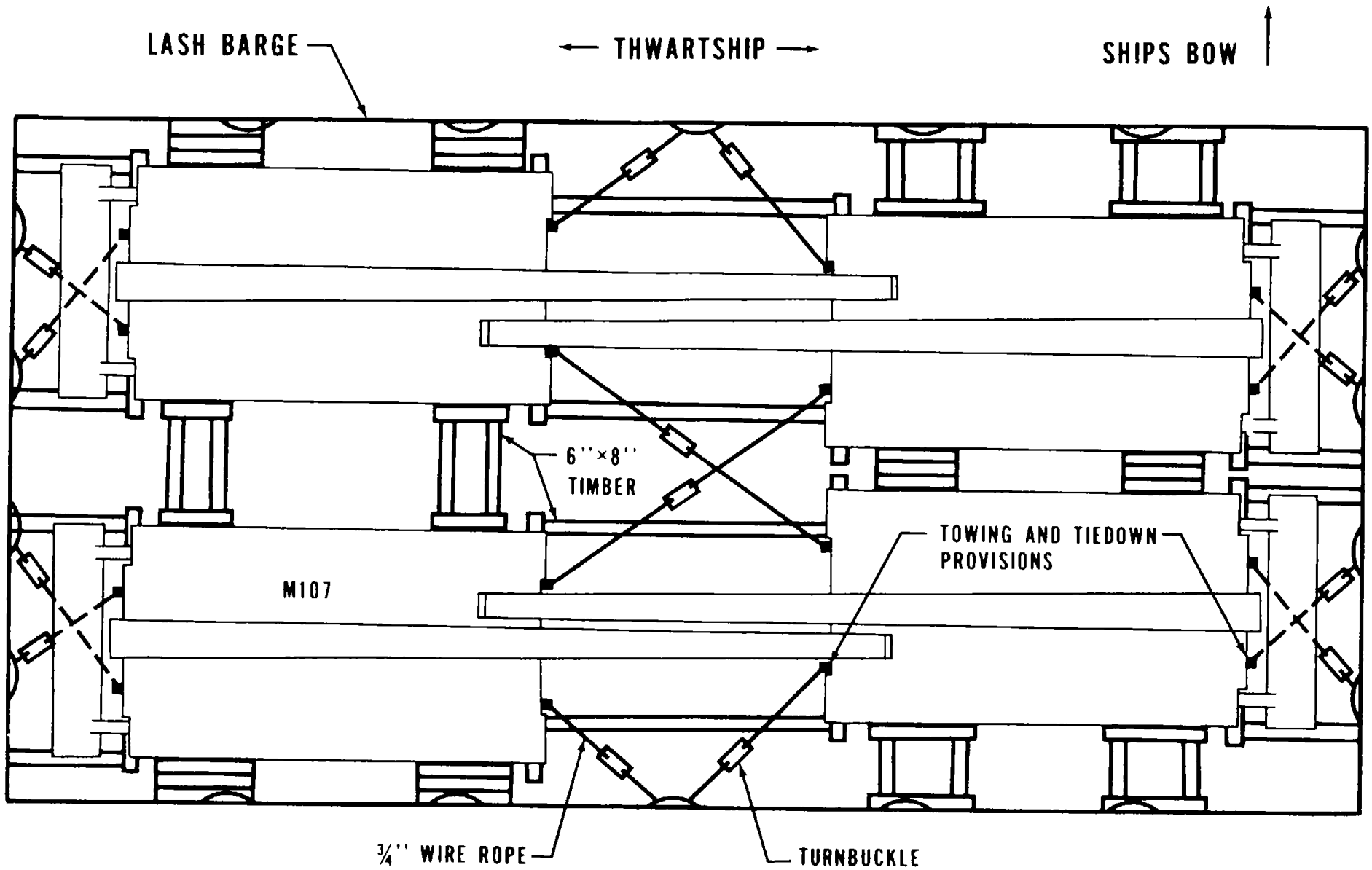

Figure 6-3. Loading of four guns, M107, on LASH barge using wire rope, cable clamps and turnbuckles, with blocking between guns and guns to hull.

CHAPTER 7

RAIL TRANSPORTABILITY GUIDANCE

Section I. GENERAL

7-1. Scope

This chapter provides transportability guidance for rail movement of the gun, M107, and howitzers, MI10 and MIIOE2. It covers significant technical and physical characteristics and safety considerations and prescribes

the materials and guidance required to prepare, load, and tie down the gun and howitzers on open top flatcars.

7-2. Maximum Utilization of Railcars

Additional cargo, approved by the activity offering the gun or howitzers for transport, may be transported with the gun or howitzers.

Section II. TRANSPORT ON CONUS RAILWAYS

7-3. General

The transportability guidance contained in this section is applicable when the gun or howitzers are transported on CONUS railways. Consideration is given to single and multiple movements on the types of railcars normally used for the transport of this type of equipment. When at a maximum width of 124 inches, the gun or howitzers can be transported without restriction and without sectionalization or major disassembly.

and tiedown. Table 7-1 provides a bill of materials and table 7-2 presents application of those materials for securing the guns or howitzers on general-purpose flatcars.

NOTE

A staggered nailing pattern should be used when lumber or laminated lumber is nailed to the floor of a railcar. The nailing pattern for an upper piece of lumber will be adjusted as required so that a nail for that piece will not be driven into or right beside a nail in the lower piece of lumber.

7-4. Preparation

The degree of preparation for shipment is dependent upon the operational commitment.

7-6. Loading on Special-Purpose Flatcars

7-5. Loading on General-Purpose Flatcars

a. The gun or howitzers can be placed in the tiedown position on a railcar by a crane of adequate capacity, or they may be driven or towed onto the railcar provided a suitable ramp or bridge is available.

a. The load shown in figures 7-4 and 7-5 is based on the use of a CONUS HTTX or similar type of flatcar. This car is equipped with special heavy-duty tiedown anchors and chain assemblies contained in channels along each side of the car and car center sill. Table 7-3 provides a bill of materials, and table 7-4 presents application of those materials for securing guns or howitzers on HTTX flatcars.

CAUTION

Do not allow gun or howitzer to exceed 3 miles per hour during loading or unloading operations.

b. The load shown in figures 7-1 and 7-2 is based on a flatcar width of 10 feet 6 inches. Fig 7-3 provides detailed instructions for blocking

b. The special-purpose cushion rub-rail flatcar is not adequate for transporting the gun, M107, and howitzers, MI10 and MIIOE2. The weight of each model exceeds the load restraint capability of the tiedown chains and cushion rub-rail.

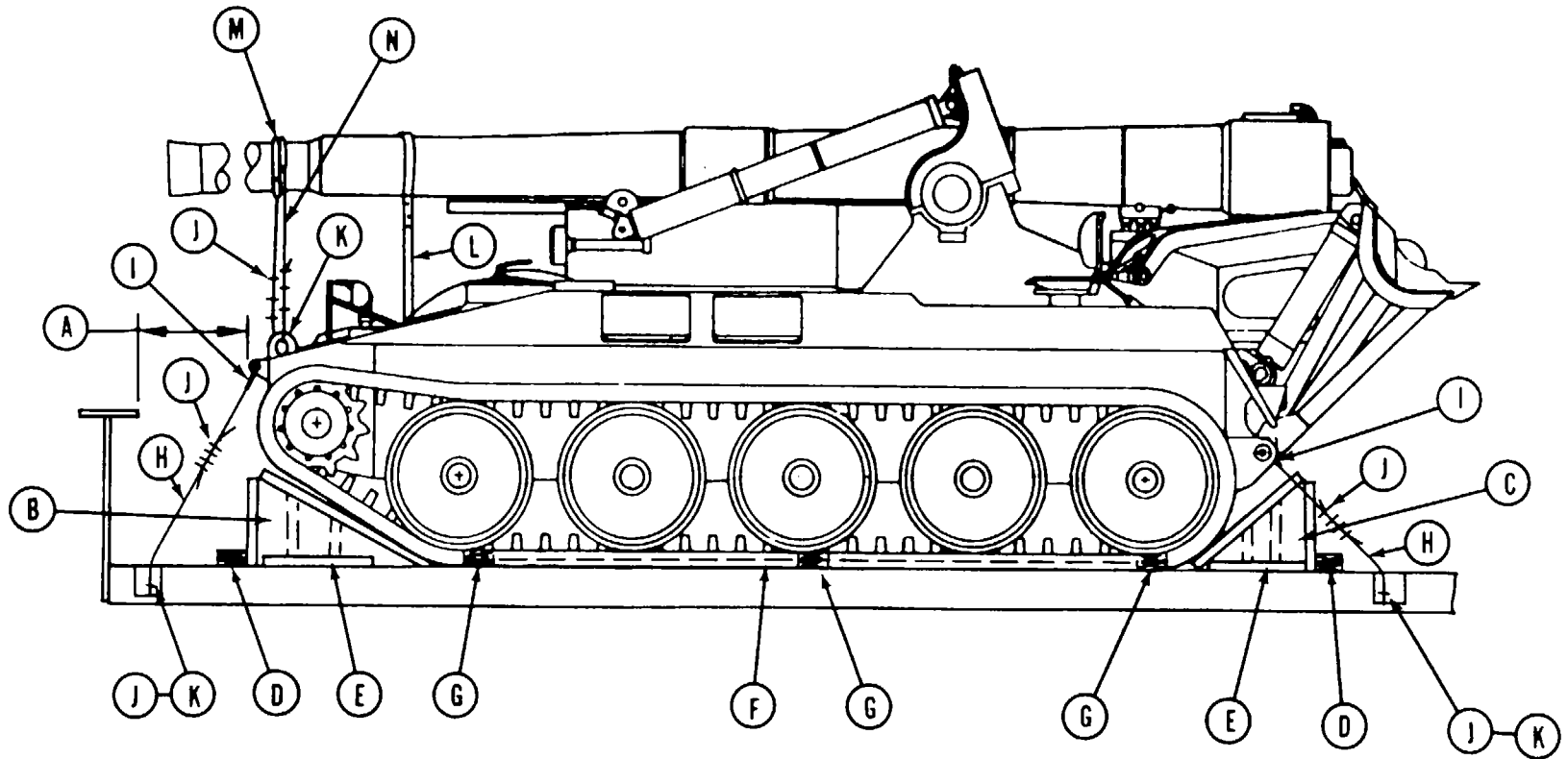

Figure 7-1. Blocking and tiedown diagram of typical gun, M107, on CONUS general-purpose flatcar (side view).

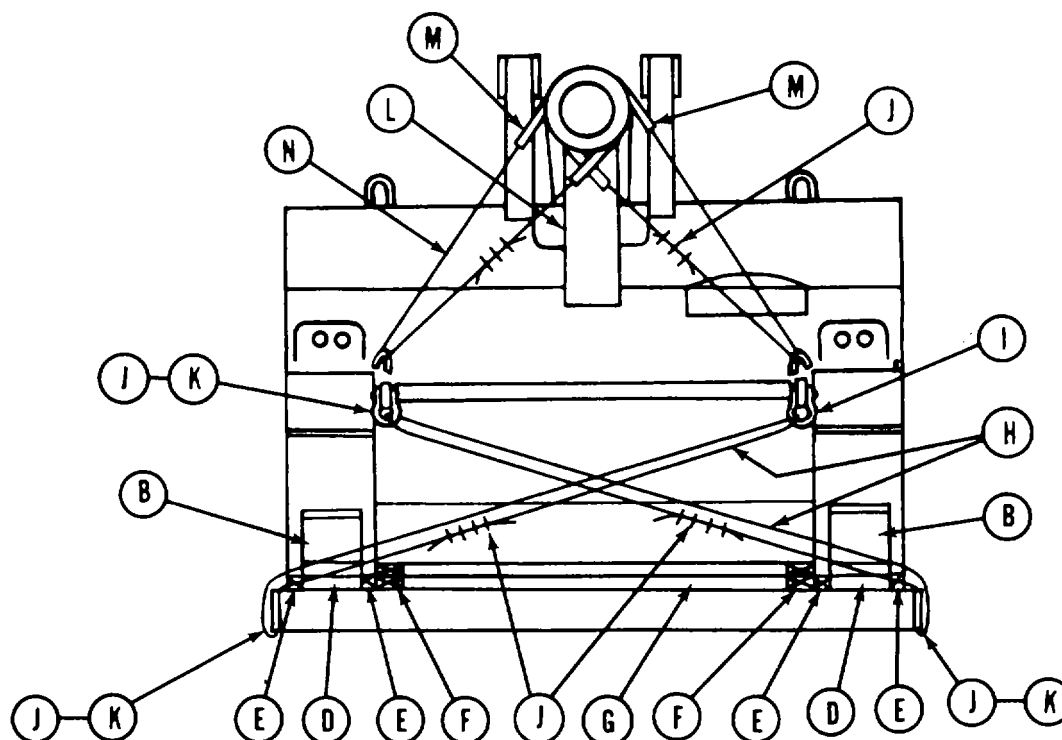
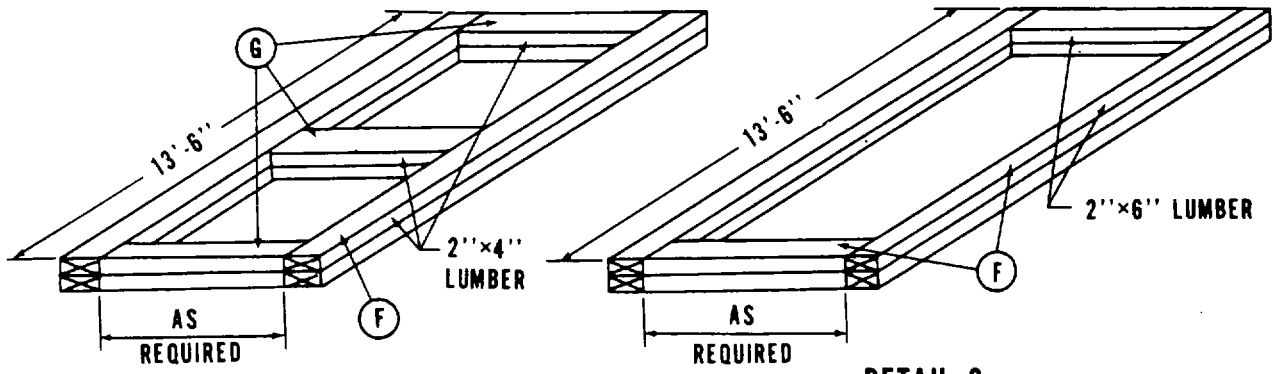

Figure 7-2. Blocking and tiedown diagram of typical gun, M107, on CONUS general-purpose flatcar (front view).

Table 7-1. Bill of Materials for Blocking and Tiedown of Typical Gun, M107 on CONUS General-Purpose Flatcar (Fig 7-1, 7-2, and 73)

Item	Description	Approximate quantity	
Lumber	Douglas-fir, or comparable lumber, straight-grain, free from material defects; Fed Spec MM-L-751H:		
	2- x 4-in.	125	linear ft
	2-x 6-in.	5	linear ft
	2- x 12-in.	65	linear ft.
Nails	Common, steel; flathead; bright or cement-coated; table XI-b, Fed Spec FF-N-105B: 30d	200	
	20d	240	
	6d	4	
Timbles	Standard, open-type: 3/8-in.	2	
	5/8-in.	16	
Clamps	Wire rope, U-bolt clips, saddled, single grip, steel, Crosby heavy-duty or equal; MIL-STD 16842:		
	3/8-in.	8	
	5/8-in.	32	
Cushioning Material	3/4-in. rubber hose (substitute if desired, waterproof paper, burlap, or other suitable material, which will prevent wire rope from damaging gun barrel).	8	ft
Steel Strapping	3/4-in., high tension.	4	ft
Shackles	Clevis assembly, suspension, bolt and nut type, large, NSN 1670-00-090-5454.	4	
Wire Rope	6x19, IWRC; improved plow steel; preformed, regular-lay; table X, Fed Spec RR-W-410C: 3/8-in.	35	ft
	5/8-in.	200	ft



DETAIL 1
FOR GENERAL-PURPOSE FLATCAR

DETAIL 2
FOR HTTX FLATCAR

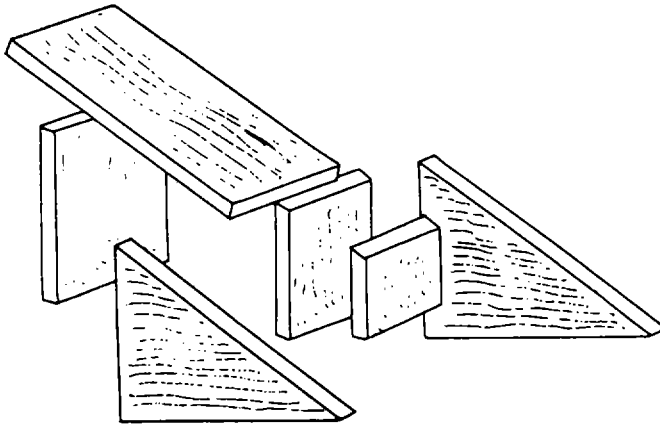

EXPLODED VIEW

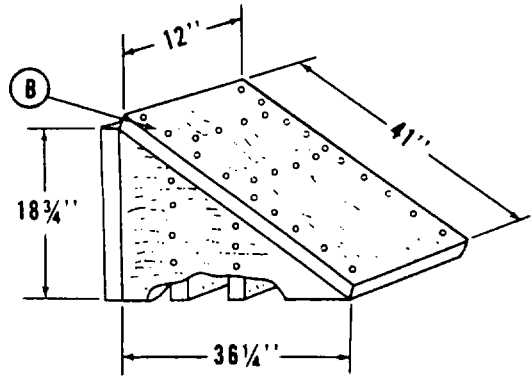

ASSEMBLED VIEW

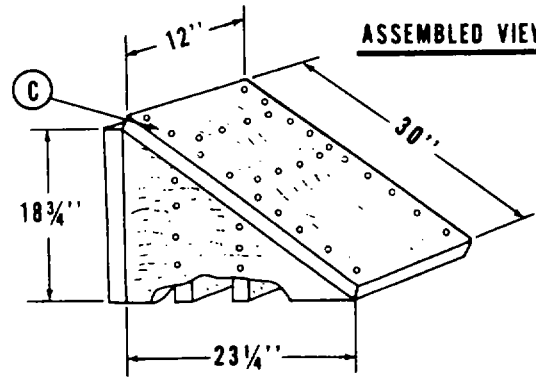

ASSEMBLED VIEW

DETAIL 3
FABRICATE BLOCKS FROM 2-x12-IN LUMBER.
USE 20d NAILS.

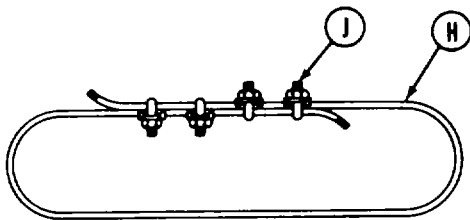

DETAIL 4

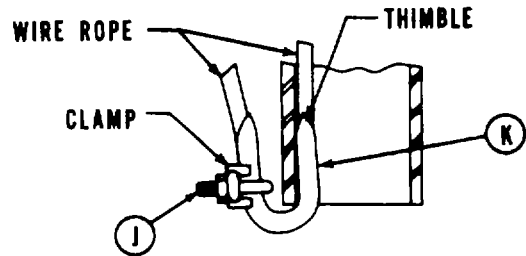

DETAIL 5

Figure 7-3. Blocking and tiedown detail diagram.

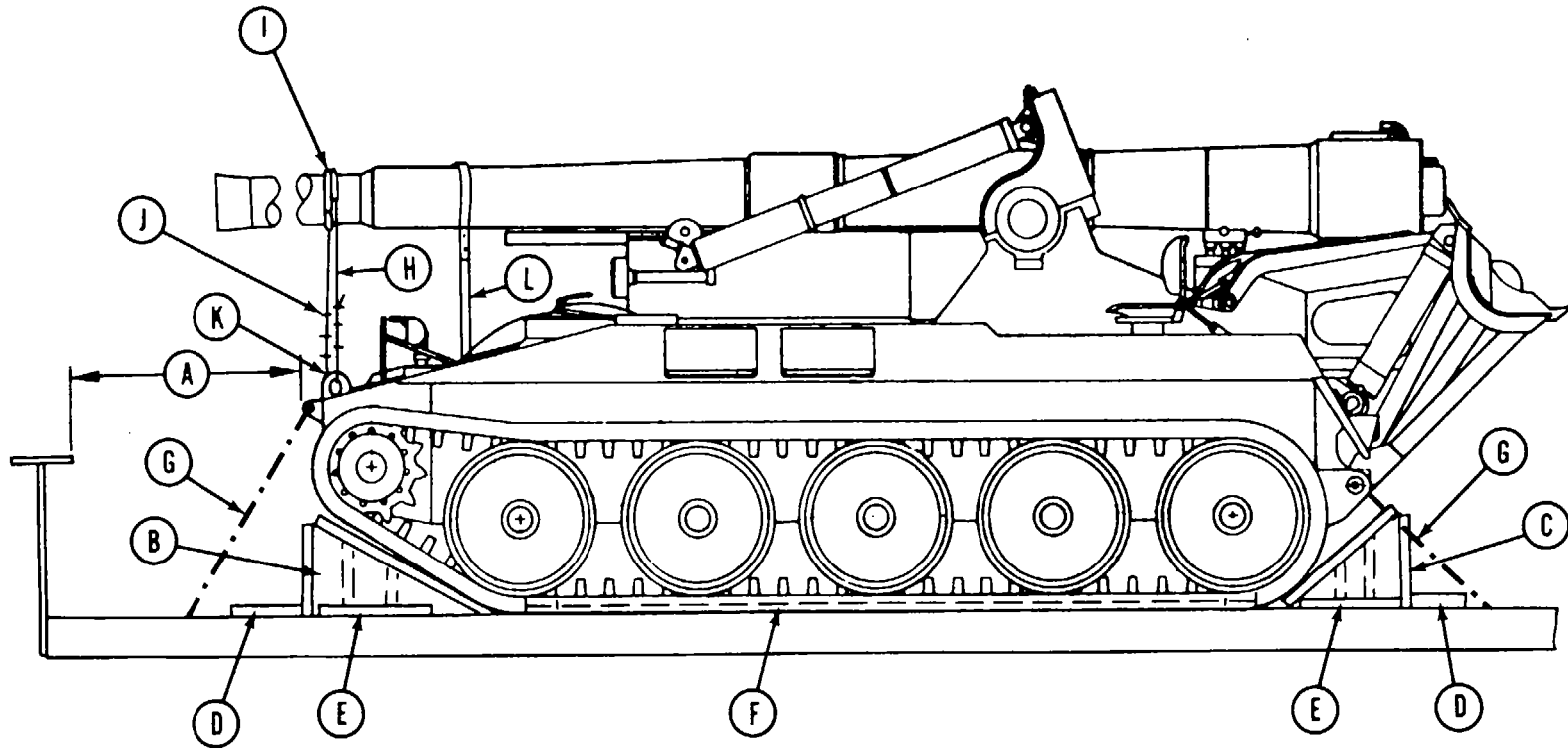

Figure 7-4. Blocking and tiedown diagram of tall gun, M107, on CONUS HTTX or similar type of flatcar (side view).

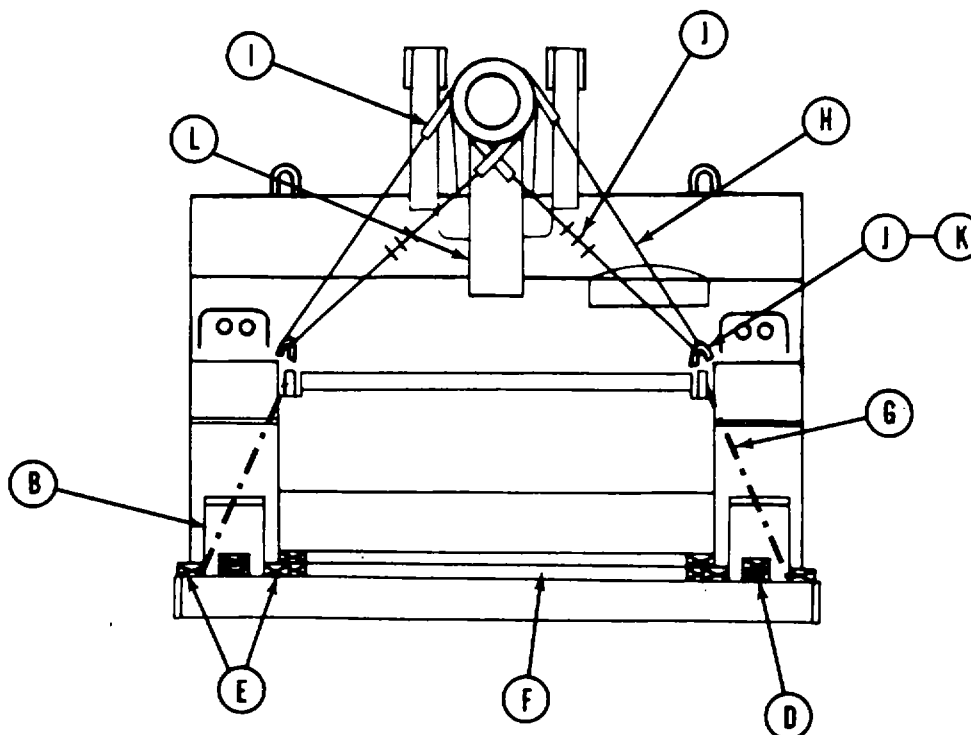

Figure 7-5. Blocking and tiedown diagram of typical gun, M107, on CONUS HTTX or similar type of flatcar (front view).

Table 7-2. Application of Materials for Blocking and Tiedown of Typical Gun, M107, on CONUS General-Purpose Flatcar (Fig 7-1, 7-2, and 7-3)

Item	No. required	Application
A		Brake-wheel clearance. Minimum clearance required is 6 in. above, in back of, and on both sides of, and 4 in. underneath wheel (fig 7-1).
B	2	Blocks (detail 3, fig 7-3). Locate one against front of each track.
C	2	Blocks (detail 3, fig 7-3). Locate one against rear of each track.
D	4	End cleat. Each to consist of two pieces of 2- x 4- x 12-in. lumber. Locate against ends of items B and C. Secure lower piece to car floor with four 30d nails and top piece to lower piece with four 30d nails.
E	8	Side cleat. Each to consist of one piece of 2- x 4- x 20-in. lumber. Locate one piece on each side of each item B and C. Secure to car floor with six 30d nails.
F	2	Frame. Each to consist of two pieces of 2- x 4-in. x 13-ft 6-in. lumber. Locate on car floor against inside edge of each track, and secure lower piece to floor with twelve 30d nails and top piece to lower piece with twelve 30d nails (detail 1, fig 7-3).
G	3	Frame. Each to consist of two pieces of 2- x 4-in. lumber long enough to fill space between items F (approximately 80 in.). Locate one near center and one at each end between items F. Secure lower piece to car floor with four 80d nails and top piece to lower piece with four 30d nails (detail 1, fig 7-3).
H	4	Wire rope. Each to consist of one piece of 5/8-in. wire rope doubled and attached through each item I and appropriate stake pocket.
I	4	Shackle. Secure one shackle to each towing lug (two at front and two at rear).
J	40	Clamp. Secure each item N with three 3/8-in. clamps. Secure each item H with four 5/8-in. clamps (detail 4, fig 7-3). Secure each item K with either a 3/8-in. or 5/8-in. clamp as appropriate.
K	18	Thimble. Locate two 5/8-in. thimbles on items H at each item I and stake pocket (detail 5, fig 7-3). Locate one 3/8-in. thimble on each item N at lifting eye.
L	1	Brace. To consist of one piece of 2- x 6-in. lumber, length as required. Apply to vehicle hull under gun barrel. Place one piece of 3/4-in. high-tension band over gun barrel, and secure to side of brace with two 6d nails.
M	2	Padding. Each to consist of one piece of 3/4-in. x 4-ft rubber hose. Thread each

Table 7-2. Application of Materials for Blocking and Tiedown of Typical Gun, M107, on CONUS General-Purpose flatcar (Fig 7-1, 7-2, and 7-3)-Continued

Item	No. required	Application
N	2	item N through hose so that hose is between gun barrel and item N. Substitute, if desired, waterproof paper, burlap, or other suitable material that will prevent wire rope from damaging gun barrel. Wire rope. Each to consist of one piece 3/8-in. wire rope, length as required (approximately 17 ft). Apply wire rope in a complete loop around gun barrel to front lifting eyes, and secure with three 3/8-in. clamps, item J.

GENERAL INSTRUCTIONS

1. The turret lock and gun elevating mechanism hand wheel must be locked and wired to prevent rotation.
2. Hand brakes must not be set.
3. Tensioning of wire rope can be accomplished with an applicable sized come-along mechanical hoist or equal tensioning device Do not over-tension wire rope around gun barrel.
4. Loading Rules . 4, 6, 7, 9, 10, 14, 15, 19, and 1-A, Section I. Association of American Railroads Rules Governing the Loading of Commodities on Open Top Flatcars and Trailers provide applicable guidance and are mandatory in application.

Table 7-3. Bill of Materials for Blocking and Tiedown of Typical Gun, M107, on CONUS HTTX or Similar Type of Flatcar (Fig 7-, 7-4, and 7-5)

Item	Description	Approximate quantity	
Lumber	Douglas-fir, or comparable lumber, straight-grain, free from material defects; Fed Spec MM-L-751H:		
	2- x 4-in.	30	linear ft
	2- x 6-in.	90	linear ft
	2- x 12-in.	65	linear ft
Nails	Common, steel; flathead; bright or cement-coated; table XI-b, Fed Spec FF-N-105B:		
	30d	200	
	20d	240	
	6d	4	
Thimbles	Standard, open-type: 3/8-in.	2	
Clamps	Wire rope, U-bolt clips, saddled, single grip, steel, Crosby heavy-duty, or equal; MIL-STD 16842: 3/8-in.	8	
Cushioning Material	3/4-in. rubber hose (substitute, if desired, waterproof paper, burlap, or other suitable material, which will prevent wire rope from damaging gun barrel).	8	ft
Steel Strapping	3/4-in., high-tension.	4	ft
Shackles	Clevis assembly, suspension, bolt and nut type, large, NSN 1670-0 0-095354.	4	
Wire Rope	6x19, IWRC;improved plow steel; preformed, regular lay; table X, Fed Spec RR-W-410C: 3/8-in.	35	ft

Table 7-4. Application of Materials for Blocking and Tiedown of Typical Gun, M107, on CONUS HTTX or Similar Type of Flatcar (Fig 7-3, 7-4, and 7-5)

Item	No. required	Application
A	-	of, Brake-wheel clearance. Minimum clearance required is 6 in. above, in back of, and on both sides and 4 in. underneath wheel (fig 7-4).
B	2	Blocks (detail 3, fig 7-3). Locate one against front of each track.
C	2	Blocks (detail 3, fig 7-3). Locate one against rear of each track.
D	4	End cleat. Each to consist of two pieces of 2- x 4- x 18-in. lumber. Locate against ends of items B and C. Secure lower piece to car floor with four 30d nails and top piece to lower piece with four 30d nails.
E	8	each Side cleat. Each to consist of one piece of 2- x 4- x 20-in. lumber. Locate one on each side of item B and C, and secure to car floor with six 30d nails.
F	1	Frame. Frame work to consist of 2- x 6-in. lumber (detail 2, fig 7-3). Locate one piece 2- x 6-in. x 13-ft 6-in. on car floor against inside edge of each track, and secure each piece with twelve 30d nails. Secure upper pieces to each lower piece with twelve 30d nails. Nails should be applied in a staggered pattern. Four pieces of 2- x 6-in. lumber cut to fit will be placed between the longitudinal pieces. Secure each lower piece to car floor with four 30d nails. Secure top to lower pieces each with four 30d nails.
G	4	pieces Chain. 1/2-in. alloy proof-tested to 27,500 lb (provided with railcar). Secure chains to tiedown shackles on front and rear of vehicle (fig 7-5). After chains are

Table 7-4. Application of Materials for Blocking and Tiedown of Typical Gun, M107, on CONUS HTTX or Similar Type of Flatcar (Fig 7-3, 7-4, and 7-5)--Continued

Item	No. required	Application
		tightened, hit sharply with a hammer to relieve any binding. Retighten if necessary. There must be at least one full wrap of chain around the tensioning device drum. If turnbuckles are used as a tensioning device they must be equipped with locknuts to prevent loosening.
H	2	Wire rope. Each to consist of one piece of 3/8-in. wire rope, length as required (approximately 17 ft). Apply wire rope in a complete loop around gun barrel to front lifting eyes, and secure with three 3/8-in. clamps, item J.
I	2	Padding. Each to consist of one piece of 3/4-in. x 4-ft rubber hose. Thread each item H through hose so that hose is between gun barrel and item H. Substitute, if desired, waterproof paper, burlap, or other suitable material that will prevent wire rope from damaging gun barrel.
J	2	Clamp. Secure each item K to each item H at front lifting eyes (detail 5, fig 7-3).
K	2	Thimble. 3/8-in. thimble attached to each item H (detail 5, fig 7-3).
L	1	Brace. To consist of one piece of 2- x 6-in. lumber, length as required. Apply to vehicle hull under gun barrel. Place one piece of 3/4-in. high-tension band over gun barrel, and secure to each side of brace with two 6d nails.

GENERAL INSTRUCTIONS

1. The turret lock and gun elevating mechanism hand wheels must be locked and wired to prevent rotation.
2. Hand brakes must not be set
3. Tensioning of wire rope can be accomplished with an applicable sized come-along mechanical hoist, or equal tensioning device. Do not over-tension wire rope around gun barrel.
4. Loading Rule 1, 2. 8. 4, S. 7. 9. 10. 14, 15. and 19-A. Section I. Association of American Railroads Rut Governing the Loading of Commodities on Open Top Flatcars and Trailers provide applicable guidance and are mandatory in application.

Section III. TRANSPORT ON FOREIGN RAILWAYS

7-7. General

The transportability guidance contained in this section is applicable when the gun or howitzers are transported on foreign railways. Consideration is given to single and multiple movements on the types of railcars normally used for the transport of this type of equipment. The gun, M107, and howitzers, M110 and M110E2, can be transported in their minimum configuration within European countries complying with the International Loading Gauge (formerly Berne International) with restrictions; also, the majority of the countries in the Middle East, South America, Australia, India, and Pakistan.

CAUTION

The spade must be lowered to the railcar floor after loading for International Loading Gauge Clearance. Further clearance considerations may be required due to the critical height of the item.

In the Middle East and South America the clearances vary, and each country will require a separate check. In Australia, India, and Pakistan,

wide- or broad-gauge railways provide greater clearances and less restrictions. Because of the various designation systems used by different countries, foreign railcars are difficult to classify. In addition, clearances vary between countries and within a country. Consequently, evaluation of transportability capability must be made on an individual basis.

7-8. Transport on US Army-Owned Foreign Service Flatcars

a. The gun and howitzers can be transported on a number of US Army-owned foreign service flatcars. These flatcars are exclusively for the transport of US military material. Table 7 presents a few of the flatcars available in Europe that are suitable for transporting this equipment.

b. The materials required for blocking and tiedown of the gun and howitzers on US Army owned foreign service flatcars are essentially the same as those used within CONUS. For general guidance, refer to figures 7-1, 7-2, and 7-3 and tables 7-1 and 7-2.

Table 7-. Characteristics of US Army-Owned European Flatcars Available for Transporting Vehicles

Flatcar designation	Capacity	Length	Width	Platform height*
SSY**	52-ton (47.17 MTON)	31-ft. 2-in. (9.50 m)	10-ft. 4-in. (3.15 m)	4-ft. 2 3/4-in. (1.29 m)
SSYS	66-ton (59.88 MTON)	31-ft. 2-in. (9.50 m)	10-ft 4-in. (3.15 m)	4-ft. 2 3/4-in. (1.29 m)
FFLM	90-ton (81.65 MTON)	46-ft. 8-in. (14.42 m)	10-ft. 3-in. (3.12 m)	4-ft. 2 3/4-in. (1.29 m)

*Above top of rail.

**German-owned SSY car are designated RIMMP.

APPENDIX A

CONVERSION TABLES

1. *Common Metric Abbreviations.*

m = meter	kg = kilogram
dm = decimeter	km = kilometer
cm = centimeter	MT - metric ton
mm = millimeter	

2. *Linear Measure.*

1 mi = 1,609.35 m	1 km = 0.6214 mi
1 yd = 0.9144 m	1 m = 1.0936 yd
1 ft = 0.3048 m	1 m = 3.2808 ft
1 in. = 0.0254 m	1 m = 39.3700 in.
1 m = 10 dm = 100 cm = 1000 mm	

3. *Surface Measure.*

1 sq yd = 0.8361 sq m	1 sq m = 1.196 sq yd
1 sq ft = 0.0929 sq m	1 sq m = 10.764 sq ft
1 sq in. = 0.00065 sq m	1 sq m = 1,550 sq in.

4. *Cubic Measure.*

1 cu yd = 0.76455 cu m	1 cu m = 1.35 cu yd
1 cu ft = 0.02831 cu m	1 cu m = 35.30 cu ft
1 cu in. = 0.000016 cu m	1 cu m = 61,023 cu in.

5. *Weight.*

1 STON = 907.185 kg	1 kg = 2.2046 lb
1 lb = 0.45359 kg	1 MT = 1,000 kg
1 MT = 2,204.62 lb	

6. The following simplified conversion factors are accurate to within 2 percent for quick computations:

- a. *Inches to centimeters*-Multiply in. by 2.54 and divide by 10.
- b. *Yards to meters*-Multiply yd by 0.9144 and divide by 10.
- c. *Miles to kilometers*-Multiply mi by 1.609 and divide by 10.
- d. *Pounds to kilograms*-Multiply lb by 0.4536 and divide by 10.

Paragraph 7-37, FM 55-15 and paragraph 2-15, TM 55-450-15 contain additional detailed conversion factors.

7. The following conversions are provided for guidance when procuring lumber, wire rope, or wire in areas that use the metric system. Lumber sizes are rounded off to nearest 1/2 cm.

a. *Lumber.*

2-in. x 4-in. x desired length = 5-cm x 10-cm x desired length
 1-in. x 6-in. x desired length = 2.5-cm x 15-cm x desired length
 6-in. x 8-in. x desired length = 15-cm x 20-cm x desired length
 1-in. x 12-in. x desired length = 2.5-cm x 30-cm x desired length
 (length normally expressed in ft or m.)

b. *Wire rope.*

3/8-in. dia = 9.5-mm dia

1/2-in. dia = 12.7-mm dia

5/8-in. dia = 15.8-mm dia

3/4-in. dia = 19.0-mm dia

7/8-in. dia. = 22.2-mm dia

1-in. dia = 25.4-mm dia

1 1/4-in. dia = 31.7-mm dia

1 1/2-in. dia = 38.1-mm dia

Round off to next higher whole mm of available wire rope sizes.

c. *Wire.*

No. 8 gauge annealed (11/64-in. dia) = 4.37-mm dia. Round off as in b above.

APPENDIX B

REFERENCES

-
1. **Army Regulations (AR)**
 - 55-29 Military Convoy Operations in CONUS.
 - 55-162 Permits for Oversize, Overweight, or Other Special Military Movements on Public Highways in the United States.
 - 55-228 Transportation by Water of Explosives and Hazardous Cargo.
 - 55-355 Military Traffic Management Regulation.
 - 70-39 Criteria for Air Transport and Airdrop of Materiel.
 - 385-40 Accident Reporting and Records.
 - 746-1 Color, Marking, and Preparation of Equipment for Shipment.

 2. **Army Field Manuals (FM)**
 - 1-100 Army Aviation Utilization.
 - 5-36 Route Reconnaissance and Classification.
 - 55-13 Air Transport of Supplies and Equipment: Standard Loads in Air Force C-5 Aircraft.
 - 56-15 Transportation Reference Data.

 3. **Army Supply Bulletins (SB)**
 - 700-20 Army Adopted/Other Items Selected for Authorization/List of Reportable Items.

 4. **Army Technical Bulletins (TB)**
 - 55-46-1 Standard Characteristics (Dimensions, Weight, and Cube) for Transportability of Military Vehicles and Other Outsize/Overweight Equipment.

 5. **Technical Manuals (TM)**
 - 5-725 Rigging.
 - 9-2300-216-10 Operators Manual: Gun, Field Artillery, Self Propelled: 175-MM, M107 (2350-436-6635) and Howitzer, Heavy, Self-Propelled: 8-inch, M110 (2350-439-6243).
 - 9-2330-294-14 Operation, Organizational, DS/GS Maintenance Manual for Semitrailer, Low-Bed, Heavy Equipment Transporter, 52 1/2-ton, XM747.
 - 38-250 (AFM 71-4) Packaging and Handling of Dangerous Materials for Transport by Military Aircraft.
 - 55-405-9 Weight and Balance.
 - 55-450-15 Air Movement of Troops and Equipment (Nontactical).
 - 55-500 Marine Equipment Characteristics and Data.
 - 55-513 Military Stevedoring.

 6. **Air Force Manuals**
 - TO 1-1B-40 Handbook of Weight and Balance Data.
 - TO 1C-6A-9 Loading Instructions USAF Series C-5 Aircraft.

NOTE

Air Force Technical Orders that have not been integrated into the Department of the Army publications system may be requisitioned through The Adjutant General's Office in accordance with AR 810-71.

7. Other Publications and Source of Procurement

Rail and Highway Shipment

Code of Federal Regulations

Title 49-Transportation, Parts 170-179

Available from: Superintendent of Documents
 US Government Printing Office
 Washington, DC 20402

Association of American Railroads Rules Governing the Loading of Commodities on Open-Top Cars

Section No. 1-General Rules

Section No. 6-Rules Governing the Loading of Department of Defense Material

Available from: Secretary, Mechanical Division
 Association of American Railroads
 ATTN: J.H. Bean
 59 E. Van Buren St.
 Chicago, Ill 606005

R. M. Graziano's Tariff No. 29 (or reissues thereof). Hazardous Materials Regulations of the Department of Transportation, Including Specifications for Shipping Containers

Available from: R. M. Graziano, Agent
 1920 L Street NW
 Washington, DC 20056

American Trucking Association, Inc., Agent

Publication ICC ATA 111-A/FMC F-1-15 (or reissues thereof).

Department of Transportation Regulations Governing Transportation of Hazardous Materials by Motor, Rail and Water, Including Specifications for Shipping Containers

Available from: Richard H. Hinchcliff, Issuing Officer
 1616 P Street NW
 Washington, DC 20036

Water Shipment

Code of Federal Regulations

Title 46-Shipping, Part 146

Available from: Superintendent of Documents
 US Government Printing Office
 Washington, DC 20402

Agent R. M. Graziano's Water Carrier Tariff No. 28 (or reissues thereof). Regulations Governing the Transportation or Storage of Explosives or Other Dangerous Articles or Substances, and Combustible Liquids on Board Vessels

Available from: R. M. Graziano, Agent
 1920 L Street NW
 Washington, DC 20036

8. Department of Transportation

Special Permit No. 3498

Commander

Military Traffic Management Command

ATTN: MTMC-SA

Washington, DC 20315

By Order of the Secretary of the Army:

Official:

VERNE L. BOWERS

Major General, United States Army

The Adjutant General

FRED C. WEYAND

General, United States Army

Chief of Staff

Distribution:

To be distributed in accordance with DA Form 12-34B, (qty rqr block no. 159). Requirements for Guns, Howitzers, and Rifles.

QUESTIONNAIRE

1. The purpose of this questionnaire is to determine the use of this manual and to obtain suggestions for its improvement.

2. As a user you are asked to complete and mail the questionnaire within 6 months of the manual publication date. Remove the page, fold and fasten it. The questionnaire is preaddressed on the reverse and requires no postage. Your cooperation is appreciated.

Please circle the appropriate answer or provide comment to the following questions:

1. Show your name (optional), grade, organization, address, and job title.
2. Manual was received 0 - 1 - 2 - 3 - 4 - 5 - 6 months after publication date.
3. How often is the manual used? Daily, weekly, monthly, never.
4. For what purpose was manual used?
 - a. Dimensional and characteristics information.
 - b. Loading guidance.
 - c. Tiedown procedures.
 - d. Other (identify).
5. What chapter(s) is(are) most useful?
1 - 2 - 3 - 4 - 5 - 6 - 7 - All - None
6. Are the manual appendices adequate? Yes No
7. Are the tables and figures comprehensible and easy to follow? Yes No
8. Is the manual of any assistance to you or your organization? Yes No
9. Does the manual provide practical guidance to personnel responsible for loading and shipping of the identified items? Yes No
10. Which mode(s) of transportation is(are) used most frequently for movement of subject items?

CONUS	Air	Hwy	Rail	Water
OVERSEAS	Air	Hwy	Rail	Water
11. Has the transportability guidance outlined in this manual resulted in the use of a mode(s) not previously used? Yes No
12. Are the loading and tiedown procedures used by:
 - a. Your organization Yes No
 - b. Commercial carriers Yes No
 - c. Other military carriers Yes No

DEPARTMENT OF THE ARMY
Military Traffic Management Command
Transportation Engineering Agency
P. O. Box 6276
Newport News, Virginia 23606
OFFICIAL BUSINESS
PENALTY FOR PRIVATE USE. 1300
MTT-TRP

POSTAGE AND FEES PAID
DEPARTMENT OF THE ARMY
DOD-314



Director
Military Traffic Management Command
Transportation Engineering Agency
ATTN: MTT-TRP, P. O. Box 6276
Newport News, Virginia 23606

- - - - -Fold here - then fasten at top - - - - -

13. The manual:
- | | | |
|---|-----|----|
| a. Provides information not previously available? | Yes | No |
| b. Supplements related manuals? | Yes | No |
14. Does this manual contradict other published manuals? Yes No
- If answer is Yes, which manuals?
15. What additional transportability guidance manuals are needed? (Specify)
16. What would you like to see added, improved, deleted, or changed in the manual?

Signature (optional)

RECOMMENDED CHANGES TO EQUIPMENT TECHNICAL PUBLICATIONS



THEN...JOT DOWN THE DOPE ABOUT IT ON THIS FORM. CAREFULLY TEAR IT OUT, FOLD IT AND DROP IT IN THE MAIL.

SOMETHING WRONG WITH PUBLICATION

FROM: (PRINT YOUR UNIT'S COMPLETE ADDRESS)

DATE SENT

PUBLICATION NUMBER

PUBLICATION DATE

PUBLICATION TITLE

BE EXACT PIN-POINT WHERE IT IS

PAGE NO.

PARA-GRAPH

FIGURE NO.

TABLE NO.

IN THIS SPACE, TELL WHAT IS WRONG AND WHAT SHOULD BE DONE ABOUT IT.

TEAR ALONG PERFORATED LINE

PRINTED NAME, GRADE OR TITLE AND TELEPHONE NUMBER

SIGN HERE

The Metric System and Equivalents

Linear Measure

1 centimeter = 10 millimeters = .39 inch
 1 decimeter = 10 centimeters = 3.94 inches
 1 meter = 10 decimeters = 39.37 inches
 1 dekameter = 10 meters = 32.8 feet
 1 hectometer = 10 dekameters = 328.08 feet
 1 kilometer = 10 hectometers = 3,280.8 feet

Weights

1 centigram = 10 milligrams = .15 grain
 1 decigram = 10 centigrams = 1.54 grains
 1 gram = 10 decigrams = .035 ounce
 1 dekagram = 10 grams = .35 ounce
 1 hectogram = 10 dekagrams = 3.52 ounces
 1 kilogram = 10 hectograms = 2.2 pounds
 1 quintal = 100 kilograms = 220.46 pounds
 1 metric ton = 10 quintals = 1.1 short tons

Liquid Measure

1 centiliter = 10 milliliters = .34 fl. ounce
 1 deciliter = 10 centiliters = 3.38 fl. ounces
 1 liter = 10 deciliters = 33.81 fl. ounces
 1 dekaliter = 10 liters = 2.64 gallons
 1 hectoliter = 10 dekaliters = 26.42 gallons
 1 kiloliter = 10 hectoliters = 264.18 gallons

Square Measure

1 sq. centimeter = 100 sq. millimeters = .155 sq. inch
 1 sq. decimeter = 100 sq. centimeters = 15.5 sq. inches
 1 sq. meter (centare) = 100 sq. decimeters = 10.76 sq. feet
 1 sq. dekameter (are) = 100 sq. meters = 1,076.4 sq. feet
 1 sq. hectometer (hectare) = 100 sq. dekameters = 2.47 acres
 1 sq. kilometer = 100 sq. hectometers = .386 sq. mile

Cubic Measure

1 cu. centimeter = 1000 cu. millimeters = .06 cu. inch
 1 cu. decimeter = 1000 cu. centimeters = 61.02 cu. inches
 1 cu. meter = 1000 cu. decimeters = 35.31 cu. feet

Approximate Conversion Factors

To change	To	Multiply by	To change	To	Multiply by
inches	centimeters	2.540	ounce-inches	newton-meters	.007062
feet	meters	.305	centimeters	inches	.394
yards	meters	.914	meters	feet	3.280
miles	kilometers	1.609	meters	yards	1.094
square inches	square centimeters	6.451	kilometers	miles	.621
square feet	square meters	.093	square centimeters	square inches	.155
square yards	square meters	.836	square meters	square feet	10.764
square miles	square kilometers	2.590	square meters	square yards	1.196
acres	square hectometers	.405	square kilometers	square miles	.386
cubic feet	cubic meters	.028	square hectometers	acres	2.471
cubic yards	cubic meters	.765	cubic meters	cubic feet	35.315
fluid ounces	milliliters	29.573	cubic meters	cubic yards	1.308
pints	liters	.473	milliliters	fluid ounces	.034
quarts	liters	.946	liters	pints	2.113
gallons	liters	3.785	liters	quarts	1.057
ounces	grams	28.349	liters	gallons	.264
pounds	kilograms	.454	grams	ounces	.035
short tons	metric tons	.907	kilograms	pounds	2.205
pound-feet	newton-meters	1.356	metric tons	short tons	1.102
pound-inches	newton-meters	.11296			

Temperature (Exact)

°F Fahrenheit temperature 5/9 (after subtracting 32) Celsius temperature °C

PIN : 012722-000